

UNIVERSITY OF IOWA  
LANDSCAPE SERVICES MANAGEMENT PLAN

---

MAY 18, 2018





# TABLE OF CONTENTS

Introduction .....	1	Maintenance Area Maps.....	39
Maintenance Area Maps .....	6	Area 1.....	41
Service Level Definition .....	7	Area 2.....	43
Level A.....	9	Area 3.....	45
Level B.....	10	Area 4.....	47
Level C.....	11	Area 5.....	49
Task Management.....	12	Area 6.....	51
Litter & Debris Control .....	12	Area 7.....	55
Turf.....	13	Area 8.....	57
Tree.....	14	Area 9.....	59
Shrub and Groundcover Bed.....	17	Appendix.....	61
Annual and Perennial Flower Bed..	18	Snow Procedure .....	63
Site Furniture & Amenities .....	19	IPM .....	64
Maintenance Terms .....	20	Tree Management .....	64
Landscape Services Calendar .....	23	Turf Program.....	66
January.....	23	Irrigation Maintenance Schedule..	67
February.....	25	Pond Management.....	68
March.....	27	Planting Detail.....	69
April.....	29	Mulching Detail .....	70
May.....	31	Post & Chain Installation.....	71
June.....	32	Retaining Wall .....	72
July.....	33	Bike Rack Installation.....	83
August.....	34	Bench Installation.....	84
September.....	35	Table Installation.....	86
October.....	36	Trash Receptacle Installation .....	88
November.....	37		
December.....	38		



## INTRODUCTION

This Landscape Services Management Plan documents the site and landscape improvements that exist on campus and provides detailed information on maintenance activities performed by Landscape Services. This plan is intended to be used to communicate in a variety of ways:

- The management plan can be used as an important communication tool with BLS customers, including Departments, facility managers, and administration. The plan provides a basis for understanding the kinds of landscapes found on campus and the level to which any given area will be maintained
- The management plan is designed to be used as a field reference tool for Landscape Services supervisors and crews. The campus is divided into nine Maintenance Areas and this plan contains individual sections for each area that can be used by staff to plan and monitor work activities. While this plan will be a useful resource, detailed task, area and staffing calculations will continue to be done using the University's geographic information system (GIS).
- It should be noted that the management plan only includes those areas of the campus for which Landscape Services has primary responsibility. The management plan does not include the hospital grounds, athletics campus or residence halls.

## **FACILITIES MANAGEMENT**

Facilities Management (FM) is responsible for the planning, construction, operation, and maintenance of general fund-supported academic and administrative support buildings, most campus grounds, and all utility systems.

### **VISION**

Always there, always the best

### **MISSION**

Providing a physical environment that promotes University excellence

### **VALUES**

#### STEWARDSHIP

We manage our resources to benefit present and future generations  
We take responsibility for our work and our actions

#### SAFETY

We believe every injury is preventable  
We work together to promote safety and wellness

#### PRIDE

We are proud of our work  
We are dedicated to serving the University of Iowa

#### INNOVATION

We continuously learn, develop and improve  
We build upon our successes and learn from our failures

#### COMMUNITY

We encourage an atmosphere of respect, trust and cooperation  
We energize and inspire each other

## LANDSCAPE SERVICES

### MISSION STATEMENT

Provide the University world - class maintenance by combining the right people, processes, and technologies for continuously optimizing service performance and efficiency.

### VISION

A campus landscape that is safe, aesthetically pleasing, well maintained and is user friendly; that is functional, inviting and memorable to students, faculty, staff and visitors.

### OBJECTIVES

**Safety and Health:** First and foremost in each and every plan of action

**Communications:** An organization that fosters open communication is one that all employees work with each other, share knowledge and skills, and are mutually responsible for the success of the organization. Good communication dictates a continuing effort and commitment.

**Maintenance:** This is the recurring, periodic or scheduled work required to preserve or restore a landscape to a condition that effectively reflects its designated purpose.

**Design:** With the University Design Standards as a guide, the Landscape Architect should have a reasoned purpose in formulating a plan for the campus landscape. The design should be flexible and effective in serving its intended purposes.

**Resources:** The University must provide the resources and guidance to allow the work to be completed efficiently and effectively with fiscal responsibility.

**Professional Development:** Skill development is an ongoing investment in staff training, not only in areas of technical skill, but also in areas of self-esteem, interpersonal dynamics and team dynamics. A comprehensive, ongoing training program will insure focused and proactive thinking staff.

**Accountability:** Each individual has a responsibility to follow the rules and procedures required, aiding in the reduction of conflict and to provide consistent guidelines to assist personnel in performing different tasks and world-class maintenance services.

# CAMPUS LANDSCAPE MAINTENANCE PLAN

The University of Iowa campus comprises over 1,700 acres of diverse landscape. Approximately 200 acres are under intense landscape management by Facilities Management, Landscape Services. In addition, Residence Services, Recreation Services, University Hospitals, Athletics and Tenant Properties provide landscape maintenance services to property surrounding their facilities.

The 2006 Campus Master Plan stated: “The visual quality of the campus has a profound influence on the quality of people’s experience at the University of Iowa. In addition, the visual quality of the campus contributes significantly to the University’s ongoing efforts to attract and retain the best students, faculty and staff, and reflect its social purpose in a positive way.” As home to over 29,000 students and almost 15,000 staff, the campus landscape must provide a variety of quality environments for people to live, work and play.

The maintenance plan is intended to develop a stronger sense of stewardship within Landscape Services. The University campus is an enduring landscape that plays an important role in the mission of the institution. Unlike most other landscape

environments, there are strong memories and attachments developed to campus spaces by those who work, study and visit here. Developing and promoting a culture in Landscape Services that recognizes the importance of a quality landscape requires each member of the Landscape Services team to share in the vision of quality and participate in creating a campus landscape that will preserve and enhance the history and future of the institution.

The University of Iowa Maintenance Plan was prepared as a tool for Landscape Services to assist in advancing the level of landscape maintenance quality on campus by:

- Defining appearance expectations
- Establishing standards for maintenance
- Providing a structure for monitoring results

The first step in improving the quality of the campus landscape is establishing a clear understanding of expectations and standards. With those expectations and standards in place, Landscape Services can program maintenance activities and monitor conformity.





## CAMPUS INVENTORY MAPS

The Campus Inventory Maps show the buildings, hardscape improvements, landscape types and site improvements that are currently tracked within the GIS system. Those elements include:

**UNIVERSITY BUILDINGS** (including projects under construction)

### HARDSCAPE IMPROVEMENTS

- Sidewalks and plazas – concrete
- Sidewalks and plazas – specialty paving
- Retaining walls / Outcropping stones
- Parking lots
- Institutional roads

### LANDSCAPE TYPES

- Turf (traditional lawns, low mow areas and prairie)
- Perennial beds
- Annual beds
- Groundcover beds
- Shrubs
- Hedges
- Mulched areas
- Wooded areas (Note: Individual trees are inventoried within the GIS system but are not included in this document for clarity)
- Roof garden areas

**SITE AMENITIES** (Note: Site improvements are inventoried within the GIS system but are not included in this document for clarity.)

- Bike racks
- Benches
- Tables
- Trash and recycling receptacles
- Building identification signs

Hardscape areas and landscape areas are measured in square feet. These areas are used in the calculation of staffing estimates for each Maintenance Area.



## MAINTENANCE AREAS

As mentioned earlier, the campus has been divided into nine (9) Maintenance Areas. These are contiguous areas which are intended to be maintained by an area grounds keeper with assistance from other crews. The sizes of the areas vary greatly depending on the amount and intensity of the individual maintenance activities contained within. In general, however, the overall work effort of any given area correlates with the staff time available to a single crew.

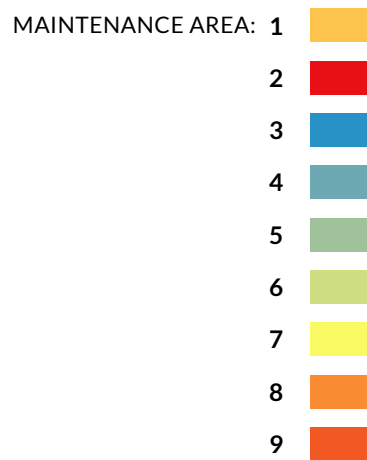
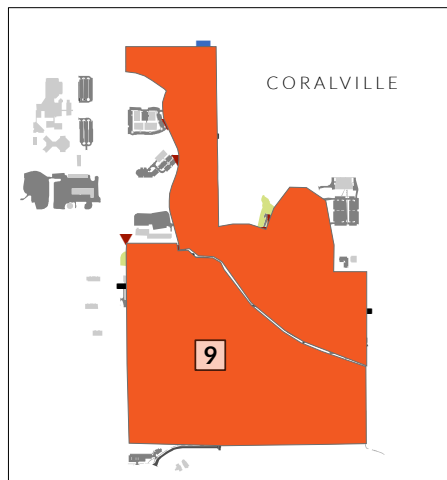

## SERVICE LEVELS WITHIN MAINTENANCE AREAS

Service Levels refer to both the amount and frequency of maintenance activities required for any given area of campus. Currently there are three levels of maintenance; Service Levels A, B and C. Certainly different parts of campus require different Service Levels. For example, the Pentacrest requires higher levels of maintenance and attention than a general academic area. In general, higher Service Levels are assigned to higher profile portions of the campus with the intent of presenting the best possible image to welcome visitors to the University and providing high quality environments for students and staff.

The following section outlines the expected maintenance outcomes for each Service Level. Included with each level is a brief discussion of design issues related to those outcomes.

### SERVICE LEVEL A

Several areas on campus are designated Service Level A. The 2006 Campus Master Plan says “The Pentacrest should be recognized and protected as the most significant character – defining feature of the campus plan. It is the historic heart of the University and the central focal point of the main campus.” As the iconic heart of the University of Iowa campus, it has historic significance for both the University and the State of Iowa. As a Service Level A area our goal is to have the Pentacrest always being outstanding in appearance with maintenance at the highest levels possible. Repairs and renovations in this Service Level would have the highest attention.

The President’s Residence, 102 Church Street, is also designated a Service Level A maintenance area. As the official residence for the University President it is used extensively for fundraising events and entertaining dignitaries from around the world. As a private residence, the need for attention to detail and more refined “residential scale” landscaping necessitates a higher level of maintenance.

### SERVICE LEVEL B

Service Level B areas represent areas of intense use by students, faculty, staff and visitors such as major pedestrian routes, gathering spaces and historically or architecturally significant buildings. In Service Level B areas we would expect maintenance levels to be above average. Service Level B areas would be designated with a simpler palette of plants with more simple arrangements as compared to Service Level A areas. Service Level B areas would have the goal of being superior in appearance.

### SERVICE LEVEL C

Service Level C areas are classified as general campus areas, open spaces or natural areas. They are characterized by large open spaces, areas adjacent to high use zones, and campus areas with moderate public exposure. In Service Level C areas, maintenance levels would be done at lower levels. Service Level C areas would be designed with very simple palette of plants with very simple arrangements or no plants at all. Service Level C areas would have the goal of being functional, simple, or natural in appearance.

## CRITERIA FOR CHOOSING SERVICE LEVEL DESIGNATIONS

### SERVICE LEVEL A

- Intense use by students and faculty at gathering places or destination points.
- Historically or architecturally significant buildings or sites.
- Significant area of interface between the University and the public (theatres, visitor areas, major administration areas, gathering places or destination points).
- Locations containing major works of art, fountains, or other unique features or landmarks.
- Identified in the Campus Master Plan as a prominent area on campus

### SERVICE LEVEL B

- Passive use by students and faculty such as open space and pedestrian circulation links between area.
- Academic or administrative buildings without historical or architectural significance but in prominent or visible locations.
- Interface between the University and the public is moderate such as borders.

### SERVICE LEVEL C

- Natural areas.
- Open space with little to no actual use by students or faculty.
- Area of little or no interface with the public or the interface is automobile oriented.

Service Level designations should be evaluated regularly to reflect changes in the campus and reductions or increases in the landscape maintenance budgets.



## SERVICE LEVEL A AREAS - HIGH INTENSITY LANDSCAPING AND MAINTENANCE

### MAINTENANCE EXPECTATIONS

- Walks, plazas, and steps are kept free of dirt and debris
- No snow storage on lawn areas
- Lawns, shrub beds, and building areas are kept free of litter
- Walks and bed lines have clean edges
- Leaves are removed promptly
- Shrub, perennial, and annual beds are kept weed free
- Perennials, annuals, trees, and shrubs are fertilized at ideal rates
- All trees and shrubs are treated for disease and insect problems in accordance with IPM of University of Iowa
- Shredded bark mulch is top dressed annually
- Trees have little to no dead wood
- Trees are pruned following ANSI standards
- Lawns are fertilized at ideal rates
- Lawns are kept free of weeds
- Lawns are maintained at approximately 3" high
- Lawns are aerified at ideal rates
- Lawns are restored/renovated promptly

### DESIGN ISSUES THAT AFFECT MAINTENANCE

- Some hand mowing and string trimming is acceptable
- High number of ornamental trees and shrubs
- High number of annual and perennial beds
- Complex foundation plantings
- Automatic irrigation in select areas, quick couplers or hose bibs for beds
- Moderate amount of brick paving

## SERVICE LEVEL A AREA FREQUENCIES

### LITTER AND DEBRIS CONTROL

Litter pick up around Area	2 x per day
Cigarette butt pick-up	2 x per week
Building entrances	5 x per week
Litter receptacles, clean and power wash	1 x per year
Sand and debris removal from walks	1 x per year

### TURF MAINTENANCE

Edging walks	2 x per year
Sidewalk margin repair	As needed
HOLGANIX application	5 x per year
Aeration	2 x per year
Mowing	1-2 x per week

### TREE MAINTENANCE

Pruning inspection	1x per month
Insect and Disease inspection	1 x per year
Mulching	1 x per year
Pre-Emergent	3 x per year

### SHRUB AND GROUND COVER BED MAINTENANCE

Trim formal hedges	3 x per year
Prune and shape shrubs	2 x per year
Edge and mulch beds	1 x per year
Weeding of beds	2 x per week
Prune dead branches and remove dead plants	2x per month
Pre-Emergent	3 x per year

### ANNUAL AND PERENNIAL FLOWER BED MAINTENANCE

Weeding	1 x per week
Edging	1 x per year
Watering, check and water as needed	3 x per week
Pre-Emergent	3 x per year

### SITE FURNITURE AND AMENITIES

Tables, benches, litter receptacles inspected	1 x per week
Post and chain inspected	2x per month
Building signs inspected	5 x per week

### IRRIGATION

See Appendix

## SERVICE LEVEL B AREAS - MODERATE INTENSITY LANDSCAPING AND MAINTENANCE

### MAINTENANCE EXPECTATIONS

- Walks, plazas, and steps are kept moderately clean
- Lawns, shrub beds, and building areas are kept moderately free of litter
- Walks and bed lines are edged monthly
- Leaves are removed regularly
- Shrub and perennial beds are kept moderately free of weeds
- Perennials, trees, and shrubs are fertilized at ideal rates
- Select trees and shrubs receive insect and disease control.
- Shredded bark mulch is top dressed every other year
- Trees have little or some deadwood
- Trees are pruned following ANSI standards
- Lawns are fertilized at ideal rates
- Lawns are on a broadleaf weed control program
- Lawns are maintained within a 3" to 6" range
- Lawns are aerified every year

### DESIGN ISSUES THAT AFFECT MAINTENANCE

- Minimal hand mowing and string trimming exist
- Moderate number of ornamental trees and shrubs
- Moderate number of perennial beds and annual beds
- Moderate amount of foundation plantings
- Minimal amount of brick paving

## SERVICE LEVEL B AREA FREQUENCIES

### LITTER AND DEBRIS CONTROL

Litter pick up around Area	5 x per week
Cigarette butt pick-up	2 x per week
Building entrances	5 x per week
Litter receptacles, clean and power wash	1 x per year
Sand and debris removal from walks	1 x per year

### TURF MAINTENANCE

Edging walks	1 x per year
Sidewalk margin repair	2 x per year
HOLGANIX application	5 x per year
Aeration	1 x per year
Mowing	1 x per week

### TREE MAINTENANCE

Pruning inspection	2 x per year
Insect and disease inspection	1 x per year
Mulching	1 x per year
Pre-Emergent	3 x per year

### SHRUB AND GROUND COVER BED

#### MAINTENANCE

Prune and shape shrubs	1 x per year
Edge and mulch beds	1 x per year
Weeding of beds	1 x per week
Prune dead branches and remove dead plants	1 x per month
Pre-Emergent	3 x per year

### ANNUAL AND PERENNIAL

#### FLOWER BED MAINTENANCE

Weeding	2 x per month
Edging	1 x per year
Watering, check and water as needed	3 x per week
Pre-Emergent	3 x per year

### SITE FURNITURE AND AMENITIES

Tables, benches, litter receptacles inspected	1 x per week
Post and chain inspected	2 x per month
Building signs inspected	5 x per week

## SERVICE LEVEL C AREAS - LOW INTENSITY LANDSCAPING AND MAINTENANCE

### MAINTENANCE EXPECTATIONS

- Walks, plazas, and steps are swept seasonally
- Lawns, shrub beds, and building areas receive litter pick up every other week
- Walks and bed lines are not edged
- Leaves are removed only as needed or not removed
- Shrub beds are weeded monthly
- Trees and shrubs receive minimal or no fertilization
- Trees and shrubs receive minimal or no insect and disease control
- Shredded bark mulch is replaced every three years
- Trees are pruned following ANSI standards
- Lawns receive no fertilizer
- Lawns receive minimal or no weed control
- Lawns are kept mowed to a 4" to 8" range or seasonally
- Lawns are not aerified

### DESIGN ISSUES THAT AFFECT MAINTENANCE

- Little hand mowing and no string trimming exist
- Minimal number of ornamental trees and shrubs
- Minimal or no foundation plantings
- No perennial or annual beds
- Little to no irrigation, hose bids on buildings
- Little to no brick paving

## SERVICE LEVEL C AREA FREQUENCIES

### LITTER AND DEBRIS CONTROL

Litter pick up around Area	2x per month
Cigarette butt pick-up	1x per month
Litter receptacles, clean and power wash	As directed
Sand and debris removal from walks	As directed

### TURF MAINTENANCE

Edging walks	1 x 2 years
Repair sidewalk margins	As directed
HOLGANIX application	As directed
Aeration	As directed

### TREE MAINTENANCE

Pruning inspection	1 x per year
Insect and Disease inspection	1 x 2 years
Mulching	As directed

### SHRUB AND GROUND COVER BED

#### MAINTENANCE

Prune and shape shrubs	1 x 2 years
Edge and mulch beds	1 x 2 years
Pre-emergent beds	1 x per year
Weeding of beds	1x per month
Prune dead branches and remove dead plants	1 x 2 months

### PERENNIAL FLOWER BED MAINTENANCE

#### *Low maintenance perennial beds only*

Weeding	1x per month
Edging	1 x 2 years
Watering, check and water as needed	As needed

### SITE FURNITURE AND AMENITIES

Tables, benches, litter receptacles inspected	2 x per year
Post and chain inspected	2 x per year
Signs inspected	1 x per year

## LITTER & DEBRIS CONTROL

### SERVICE LEVEL A

1. Litter and debris will be picked up a minimum of twice per day.
2. Cigarette butts will be picked up from pavement and mulch beds twice per week.
3. Building entrances, stairways and major gathering spaces will be checked daily and kept free of litter and debris as needed.
4. All sidewalks and steps will be cleaned, blown and / or swept after each mowing.
5. Litter receptacles and pavement under receptacles will be cleaned & power washed once per year.
6. Any debris resulting from storms will be cleaned up immediately following the storm and completed by the day following the occurrence.

### SERVICE LEVEL B

1. Litter and debris shall be picked up a minimum of 2 times per week and in extremely high use areas more frequently as needed.
2. Cigarette butts will be picked up from pavement and mulch beds a minimum of twice per month.
3. Building entrances, stairways and major gathering spaces will be checked two times per week and kept free of litter and debris as needed.
4. All sidewalks and steps will be cleaned, blown or swept after each mowing.
5. Litter receptacles and pavement under receptacles will be cleaned & power washed once every two years.
6. Any debris resulting from storms will be cleaned up as soon as possible following a storm event.

### SERVICE LEVEL C

1. Litter and debris shall be picked up a minimum of once every two weeks.
2. Cigarette butts shall be picked up from pavement and mulch beds a minimum of once a month.
3. Major gathering spaces will be checked every two weeks and kept free of litter and debris as needed.
4. Any debris resulting from storms will be cleaned up when possible.



## TURF MANAGEMENT

### SERVICE LEVEL A

1. Litter in turf areas will be picked up prior to mowing.
2. Mowing shall be scheduled so that no more than one third (1/3) of the grass blade is removed with an ideal cutting height of 3 ½”.
3. Irrigation shall be used as required to maintain a weekly application rate on one (1) inch from rainfall and irrigation during the growing season.
4. Edging walks shall be done a minimum of 2 times per season.
5. HOLGANIX (organic fertilizer mixed with minimal pesticides) to be applied 5 times, 6 weeks apart starting in April.
6. Aeration shall be scheduled each spring and fall in high use area to maintain quality turf.
7. Leaf litter may be mulched in place with mowers throughout the fall as necessary. Leaves will be removed promptly. Leaves will be hauled to the compost pile on the Hawkeye campus.
8. Grass clippings and mowing debris will be removed from all paved surfaces immediately after each mowing.
9. Renovations shall be addressed as soon as damage occurs to keep turf and walk edges free of bare spots and worn pathways. All sidewalk edges will be top dressed and sodded without delay once ground conditions permit in the spring.
5. Aeration shall be scheduled each fall and more frequently in high use area to maintain quality turf.
6. Leaf litter may be mulched in place with mowers throughout the fall as necessary. Leaves will be removed when their volume / depth is such that it may kill the grass or cause other problems. Leaves will be hauled to the compost pile on the Hawkeye campus.
7. Renovations shall be addressed on an as need basis to keep turf and walk edges free of bare spots and worn pathways. All sidewalk edges will be top dressed and seeded before Spring Semester graduation.
8. Grass clippings and mowing debris will be removed from all paved surfaces immediately after each mowing.

### SERVICE LEVEL B

1. Litter in turf areas will be picked up prior to mowing.
2. Mowing shall be scheduled so that no more than one third (1/3) of the grass blade is removed with an ideal cutting height of 3 ½”.
3. Edging walks shall be done a minimum of one time per season.
4. HOLGANIX (organic fertilizer mixed with minimal pesticides) to be applied 5 times, 6 weeks apart starting in April.
5. Aeration will not be performed in this level unless scheduled to address a significant turf issue.
7. Renovations will be addressed on an as need basis when time allows.
8. Leaf litter may be mulched in place with mowers throughout the fall if necessary.

### SERVICE LEVEL C

1. Litter in turf areas will be picked up prior to mowing.
2. Mowing shall be scheduled every 10 days with a target height of 4”.
3. Edging walks shall be done every 2 to 3 years.
4. All fertilizing and herbicide applications will be done only when directed by supervisor.
5. Weed control will be utilized only to manage noxious weeds and heavy infestations of invasive weeds.
6. Aeration will not be performed in this level unless scheduled to address a significant turf issue.
7. Renovations will be addressed on an as need basis when time allows.
8. Leaf litter may be mulched in place with mowers throughout the fall if necessary.

# TREE MANAGEMENT

## GENERAL TREE MANAGEMENT STANDARDS

### ARE:

1. Tree selection should be based on the 10-20-30 Rule where there is no more than 10% of one Species, 20% of one Genus, or 30% of one Family comprising the campus forest.
2. The Campus Urban Forestry Study that was prepared by the Jeffrey L. Bruce & Co. for the University of Iowa in 1996 will be referred to for tree selection recommendations along with recommendations by the Campus Landscape Architect and Arborist.
3. Tree pruning will vary depending on the Service Level, but in general trees should be pruned to:
  - a. follow ANSI A300 Standards
  - b. provide pedestrian and vehicle clearance
  - c. follow the appropriate time of year for Oaks and Elms.
4. Pesticide applications will follow the Landscape Services Integrated Pest Management guidelines.
5. Dead trees will be removed as soon as possible.
6. Trees will be installed in Service Level A Areas first, followed by Service Level B areas, and then Service Level C areas.
7. Watering of newly-installed trees will occur as needed for the first two years after planting.

## SERVICE LEVEL A

1. Trees will be inspected monthly for pruning needs.
2. Trees will be inspected monthly for insect and disease concerns or during the appropriate life cycle of the pest.
3. Trees will be mulched annually.
4. Minimum caliper for new tree installations will be 2 inches.

## SERVICE LEVEL B

1. Trees will be inspected twice per year for pruning needs.
2. Trees will be inspected once per year for insect and disease concerns.
3. Trees will be re-mulched every other year.
4. Minimum caliper for new tree installations will be 2 inches.

## SERVICE LEVEL C

1. Trees will be inspected once a year for pruning needs.
2. Trees will be inspected every other year for insect and disease concerns
3. Trees will be re-mulched as directed



## TREE MANAGEMENT

Landscape Services is responsible for the management of over 6,500 trees on the main campus and over 1,500 trees on the Oakdale campus. Criteria to manage the UI urban forest are as follows.

### INSTALLATION

The selection of tree species and planting sites for campus tree installation by Landscape Services staff will be done collaboratively among the Landscape Architect, Landscape Designer, Grounds Supervisor and Arborist.

Service Level A areas will have new tree plantings scheduled and installed first.

Service Level B areas will have new tree plantings scheduled and installed second.

Service Level C areas will have new tree plantings scheduled and installed last.

### PRUNING, MONITORING AND REMOVAL CONSIDERATIONS

Pruning practices shall follow the American National Standards Institute (ANSI) A300 standards. General pruning of oaks and elms shall be done between the months of November through March to minimize the spread of Oak Wilt and Dutch Elm disease.

Service Level A areas shall be inspected annually for tree pruning needs, monitoring for insect and disease problems, and removal considerations.

Tree pruning shall be given to hazard trees. Pruning priorities for clearance, removal of dead wood, structural and aesthetic reasons will follow. Clearance over sidewalks shall be 8 feet and clearance over streets shall be 14 feet for medium to mature sized trees per ANSI A300 standards. Scheduling will be done by the Landscape Services Arborist and Grounds Supervisor.

Monitoring for insects and diseases shall be done based on the tree species that could be affected and the season of the year. Treatment decisions will be determined by severity of the potential tree damage both physically and esthetically.

Tree removal considerations shall be determined based on discussion among the Arborist, Grounds Supervisor, Landscape Designer and Landscape

Architect. If a decision is made to remove a tree from a Service Level A area, the appropriate communication will be made to the various stakeholders before the tree is scheduled for removal.

Service Level B tree pruning shall be given to hazard trees first followed by clearance, dead wood, structural and aesthetic considerations. The same clearance standards stated for Service Level A shall be followed for Service Level B.

Service Level C tree pruning Service shall be given to hazard trees first. Pruning for clearance, removal of dead wood, structural, and esthetic reasons will be done after Service Level A and B areas are complete. Special circumstances could push pruning and removal of Service Level C ahead of Service Levels A and B. The Clearance standards stated in Service Levels A and B shall be followed in Service Level C.

### WATERING

Watering of newly-installed trees shall occur as needed for two years after planting, This applies to Service Levels A, B and C.

### MULCHING

All trees growing in the maintained portions of campus shall have a mulch circle with a minimum radius of three feet. The purpose of the mulch circle is to protect the tree trunk from mower and weed eater damage as well as protecting the tree roots by retaining moisture and lowering soil temperatures. The outer edge of the mulch circle shall have a three to four inch edge dug to keep the mulch from encroaching into the turf and to have a level interface with the turf. The mulch depth shall not exceed four inches.

Service Level A areas with trees shall have mulch circles and will be refreshed annually.

Service Level B areas with trees shall have mulch circles and will be refreshed as needed once Service Level A is complete.

Service Level C areas will be scheduled after Service Level A and B areas are complete.

## TREE INVENTORY

An electronic tree inventory is used as a management tool for maintaining the campus trees. The inventory can be found at: <https://maps.facilities.uiowa.edu/trees/>  
The tree inventory will identify trees on the Heritage Tree Walk, memorial trees, donated trees and state champion trees located on campus. Information will include date of installation, genus / species / cultivar, maintenance activity, removal dates, photos and a link to Wikipedia.



## SHRUB AND GROUND COVER BED MANAGEMENT

### GENERAL SHRUB AND GROUND COVER STANDARDS ARE:

1. Plant selection should minimize the need to shear or prune shrubs
2. Shrub pruning will vary depending on the Service Level but in general shrubs should be pruned to:
  - a. maintain size and shape
  - b. provide pedestrian clearance
  - c. provide safe visual exposure of pedestrians at building entrances and other high traffic areas
  - d. encourage flowering
  - e. promote safe, healthy plants
  - f. provide a specified design statement
3. Hedge plantings shall be trimmed regularly in accordance with the plant type and growth rate
4. Height and form shall be determined by Campus Landscape Architect
5. Ornamental grasses shall be cut off three to six inches above the crown in early spring prior to new growth
6. Groundcover should be managed to promote vigorous growth, minimize weeds and control pests

### SERVICE LEVEL A

1. Formal hedge plantings will be sheared three times per season
2. Shrubs shall be pruned and shaped two times per season
3. Shrub beds will be edged and mulched as soon as possible in the spring, no later than spring graduation.
4. Pre-emergent will be applied three times per season within the shrub beds
5. All shrub and groundcover beds will be kept free of weeds
6. Any plant material that is dead or dying will be immediately removed and replaced

### SERVICE LEVEL B

1. Shrubs shall be pruned and shaped once per season
2. Shrub beds shall be edged and mulched once per season
3. Pre-emergent shall be applied three times per season
4. All shrub and groundcover beds will be weeded weekly
5. Any plant material that is dead or dying shall be removed within two weeks and replaced as soon as possible

### SERVICE LEVEL C

1. Shrubs shall be pruned and shaped once every two to three years
2. Shrub beds shall be edged and mulched once every two years
3. Pre-emergent shall be applied twice per growing season
4. All shrub and groundcover beds shall be weeded once a month
5. Any plant material that is dead or dying shall be removed within several weeks and replaced within the proper planting window



# ANNUAL AND PERENNIAL FLOWER BED MANAGEMENT

## GENERAL ANNUAL AND PERENNIAL STANDARDS ARE:

1. Annual flower beds are only planted in Service Levels A & B
2. Fall mums shall be planted at Landscape Services discretion in the following order:
  - a. Pentacrest
  - b. President's Residence
  - c. Library
  - d. IMU Fountain
  - e. PBDB
  - f. Hubbard Park
  - g. Other locations to be selected
3. Annual flower beds shall be thoroughly prepared to a minimum depth of 8" prior to planting by incorporating decomposed organic matter
4. Pre-emergent (Snap Shot, Broadstar) and slow release fertilizer shall be applied to planting beds in April, July and September
5. Watering of flower beds shall be done regularly and adequately to fit the weather, soil and plant conditions needs
6. Insect and disease control shall occur as needed to maintain healthy plants in all situations
7. Perennial beds shall receive an application of pre-emergent and slow release fertilizer in March. A second application of pre-emergent will be applied June and final application of pre-emergent will be applied in September
8. Pruning of herbaceous perennials shall consist of removing previous years top growth in spring prior to any new growth. Beds shall be cleaned and mulched with one inch of chocolate brown processed mulch
9. Prune foliage from spring flowering bulbs after wilting

## SERVICE LEVEL A

1. Annuals in Service Level A will be planted prior to spring graduation in the following order
  - a. Pentacrest

- b. President's Residence
- c. Main Library
- d. Nursing Circle
- e. IMU

2. Spring flowering bulbs may be planted in key Service Level A locations at discretion of the Campus Landscape Designer
3. Remove foliage after dieback
4. Dead heading will be performed on varieties which require it to promote maximum blooming only in Service Level A
5. Hand weeding of annual beds will be done once a week
6. Edging of annual beds will be done monthly

## SERVICE LEVEL B

1. Annuals in Service Level B will be planted by in the following order with the intent of having all installations completed by spring graduation weather and ground conditions permitting:
  - a. Dental Science
  - b. Medical Campus
  - c. Theatre Building
  - d. Phillips Hall
  - e. Boyd Law
  - f. Additional annual beds and planters may be installed in Service Level B at the discretion of the Campus Landscape Architect
2. Spring flowering bulbs may be planted in key Service Level B locations at the discretion of the Campus Landscape Designer
3. Hand weeding of beds in Service Level B areas shall be done every two weeks
4. Edging of annual beds shall be done every other month

## SERVICE LEVEL C

1. Minimal low maintenance perennial flower beds may be used in Service Level C areas

## SITE FURNITURE & AMENITIES MANAGEMENT

It is the responsibility of each Area Groundskeeper to monitor and inspect the quality and condition of all site furniture and amenities in their assigned area. This includes benches, tables, litter receptacles, building signs, fences and post & chain barriers.

### SERVICE LEVEL A

All site furniture and amenities will be kept in excellent condition at all times. Excellent condition is interpreted to mean:

- Painted metal free of scratches, mars and defects that can cause rusting
  - Wood bench slats are free of splinters, breaks and graffiti
  - Litter receptacles are clean and well maintained
  - All fixtures and amenities that are designed to be anchored are well secured
  - All postings are removed from light poles, litter receptacles and anything else as soon as noticed
  - Building signs are clean and free of graffiti
  - Fences are kept mostly free of rust and damage. They are secure and in a level upright condition
  - Post & Chain barriers are not sagging and posts are upright
1. Inspect all site furniture and amenities every two weeks
  2. Report any maintenance issues immediately when noticed
  3. If necessary, remove immediately
  4. Repairs & replacement should be completed within a two week minimum

### SERVICE LEVEL B

All site furniture and amenities will be kept in good condition at all times. Good condition is interpreted to mean:

- Painted metal is mostly free of scratches, mars and defects that can cause rusting
- Wood bench slats are free of splinters, breaks and graffiti
- Litter receptacles are clean and well maintained

- All fixtures and amenities that are designed to be anchored are well secured
- All postings are removed from light poles, litter receptacles and anything else within three days
- Building signs are clean and free of graffiti
- Fences are kept mostly free of rust and damage. They are secure and in level upright condition
- Post & chain barriers are not sagging and posts are upright

1. Inspect all site furniture and amenities at least once a month
2. Report any maintenance issues immediately when noticed
3. If necessary, removal should be accomplished within three days
4. Repairs and replacement should be completed within one month

### SERVICE LEVEL C

All site furniture and amenities will be kept in fair condition at all times. Fair condition is interpreted to mean:

- Painted metal is relatively free of scratches, mars and defects that can cause rusting
  - Wood bench slats are mostly free of splinters, breaks and graffiti
  - Litter receptacles are mostly clean and well maintained
  - All fixtures and amenities that are designed to be anchored are well secured
  - All postings are removed from light poles, litter receptacles and anything else two times per year
  - Building signs are clean and free of graffiti
1. Inspect all site furniture and amenities at least once per year
  2. Report any maintenance issues immediately when noticed
  3. Removal should be accomplished as soon as possible unless safety issue is identified and the removal should be scheduled within three days

## DEFINITIONS OF MAINTENANCE TERMS

The following terms are used throughout the management plan and have been defined as follows:

### **HAND WEEDING -**

Mechanical methods will include the complete removal of noxious weeds and other foreign material. Removal will include as much of the root system as possible.

### **CHEMICAL WEEDING -**

Weeding of planting beds, annual beds and perennial beds using chemical methods will include the application of herbicides, both pre and post emergent, to all noxious weeds and other foreign plant material. The Grounds Supervisor will determine the type of chemical control and application rates.

### **WATERING -**

Watering of planting beds, annual beds, and perennial beds will include the regular application of water at a rate determined by the Grounds Supervisor.

### **FERTILIZING -**

Fertilizing of planting beds, annual beds, and perennial beds will include the application of fertilizers at a rate determined by the Grounds Supervisor.

### **MULCHING -**

Mulching of planting or perennial beds will include the application of processed mulch at a depth not to exceed 4". Mulch should always be applied at minimum depths and should not be allowed to come in contact with the root collar of trees or shrubs. After application mulch is to be smoothed within the beds and edges raked to create a crisp transition between the mulch area and surrounding land uses.

### **TRIMMING HEDGES -**

Trimming hedges includes the shearing of plant material into formal geometric forms.

### **PRUNING -**

Pruning of planting beds will include the removal of broken, diseased or insect damaged branches. It will also include the removal of crossing branches or other branches necessary to promote vigorous and functional growth and form.

### **MONITORING -**

Monitoring planting beds, annual beds and perennial beds will include inspection of the plants for disease, insect, or other problems, deadheading of spent flowers and stems, removal of dead leaves, and pruning of broken branches.

### **CLEANUP OF ANNUAL BEDS -**

Cleanup of annual beds will include the removal of annual plants from previous growing season to make way for annual plants from the current growing season. The removal of bulbs for summer annuals, the removal of summer annuals for fall annuals and the removal of fall annuals for spring bulbs are a few examples.

### **PREPARATION OF ANNUAL BEDS -**

Preparation of annual beds will include the amending of soil, tilling, fertilizing or other work necessary to prepare the bed for annual flowers.

### **PLANTING OF ANNUAL BEDS -**

Planting of annual beds will include the installation of annual plants such as bulbs, summer annuals or fall annuals.

### **BLOW / SWEEP PAVEMENT -**

Blowing or sweeping pavement will include the complete removal of dirt, sand or other debris from pedestrian paving surfaces by using power blowers, brooms or both. Debris should be removed from flat surfaces of paving, corners between paving and walls, the tops of walls if visible, from under site furniture, from stair treads and risers and handicap ramps.



### **CLEAN SITE FURNITURE -**

Cleaning site furniture will include the complete removal of postings, flyers, tape, stickers or other foreign objects from benches, tables, litter receptacles and bollards.

### **LITTER PICK UP -**

Litter pick up will include the complete removal of all trash or other foreign objects from paved areas, lawns, steps and ramps. Litter pick up will also include the removal of visible trash from planting beds, annual beds and perennial beds.

### **LEAF REMOVAL -**

Leaf removal will include removing leaves from lawns, planting beds, perennial beds and annual beds.

### **ANNUALS IN CONTAINERS -**

The complete care of annual plants that are in free standing containers. Care will include weeding, watering and monitoring.

### **CUTTING BACK PERENNIALS -**

Cutting back perennials will include the removal of dead organic material at the end of the growing season. Perennials with winter interest can be left throughout the winter season at the direction of the Grounds Supervisor.





# LANDSCAPE SERVICES CALENDAR

## JANUARY

### ALL STAFF:

- Monitor Compliance Training requirements
- Clean vehicles weekly

### AREA GROUNDSKEEPERS:

- Snow removal, as weather dictates. Check for slippery areas each morning on non-snow days.
- Litter and debris removal
- Winter Projects List – tree work, prairie and savanna management

### OAKDALE CAMPUS:

- Snow removal, as weather dictates. Check for slippery areas each morning on non-snow days.
- Litter and debris removal
- Winter Projects List – tree work

### TREE CREW:

- Snow removal, as weather dictates. Assist Area Gk's w/ monitoring of slippery areas, as needed.
- Winter Projects List – tree work, prairie and savanna management
- Submit burn permit w/ Iowa City Fire Dep't. for prairie burn
- Submit burn permit w/ Coralville Fire Dep't. for prairie burn at Oakdale Hygienic Lab, if intended for this year
- Tree inventory
- Register for Shade Tree Short Course held in Ames in February
- Work on the Pentacrest trees as ground conditions allow
- Perform tree work based on tree management plan found in Tree Campus USA Submittal

### TURF CREW:

- Snow removal, as weather dictates. Assist Area Gk's w/ monitoring of slippery areas, as needed.
- Winter Projects List – tree work, prairie & savanna management
- Attend Iowa Turfgrass Conference for those approved

### IRRIGATION SPECIALIST:

- Snow removal as weather dictates
- Assist Area Gk's with monitoring slippery areas, as needed
- Winter Projects List - tree work, prairie and Savanna management
- Design of irrigation systems

### INSTALLATION CREW:

- Snow removal, as weather dictates. Assist Area Gk's w/ monitoring of slippery areas, as needed.
- Plan and discuss designs for upcoming planting season w/ LS Manager. Order flowers.
- Greenhouse work for Spring installations – annuals, tender perennials, vertical walls, etc.

### CONCRETE CREW:

- Snow removal, as weather dictates.
- Interior concrete projects for other departments, as requested.
- Clean and organize forms

### PROJECTS CREW:

- Snow removal, as weather dictates
- Sign maintenance, site furniture, post and chain inspection
- Assist internal units, Utilities and other Shops as requested

**WASTE MANAGEMENT:**

- Snow removal, as weather dictates
- Garbage truck routes
- Litter Receptacle routes
- Roll-off and compactor routes

**MECHANICS:**

- Snow removal, as weather dictates
- Service and repairs

**SUPERVISOR:**

- Snow Reports
- Monitor snow melt systems
- Planning and scheduling
- Monitor Compliance Training requirements for self and staff
- AiM - Approve time entries, assign new work requests, close completed work requests
- Track warehouse stock data entry / equipment rental usage
- Performance Appraisals
- Register for Shade Tree Short Course held in Ames in February
- Monitor progress of Winter Projects List
- Tree seedling operation in Micronursery
- Register Groundskeeper II's, Arborist, Tree Trimmers, and Supervisor for Continuing Instruction Course at Johnson County Extension
- Submit Quarterly Absence Log to FM - HR

# LANDSCAPE SERVICES CALENDAR

## FEBRUARY

### ALL STAFF:

- Monitor Compliance Training requirements
- Clean vehicles weekly

### AREA GROUNDSKEEPERS:

- Snow removal, as weather dictates. Check for slippery areas each morning on non-snow days.
- Litter and debris removal
- Winter Projects List – tree work, prairie & savanna management

### OAKDALE CAMPUS:

- Snow removal, as weather dictates. Check for slippery areas each morning on non-snow days.
- Litter and debris removal
- Winter Projects List – tree work

### TREE CREW:

- Snow removal, as weather dictates. Assist Area Gk's w/ slippery areas, as needed.
- Winter Projects List – tree work, prairie and savanna management, complete burn permit w/ Iowa City Fire Department for prairie burn
- Tree inventory
- Attend Shade Tree Short Course at Iowa State University for those approved
- Work on the Pentacrest as ground conditions allow
- Organize Tree Campus USA Service Learning Projects w/ student groups
- Prepare and prioritize projects for upcoming season
- Perform tree work based on Tree Management Plan found in Tree Campus USA submittal

### TURF CREW:

- Snow removal, as weather dictates. Assist Area Gk's w/ slippery areas, as needed.
- Winter Projects List – tree work, prairie and savanna management

### IRRIGATION SPECIALIST:

- Snow removal as weather dictates
- Assist Area Gk's with monitoring slippery areas, as needed
- Winter Projects List - tree work, prairie and Savanna management
- Design of irrigation systems

### INSTALLATION CREW:

- Snow removal, as weather dictates. Assist Area Gk's w/ slippery areas, as needed
- Greenhouse work for Spring installations – annuals, tender perennials, vertical walls, etc.
- Prairie & savanna management

### CONCRETE CREW:

- Snow removal, as weather dictates.
- Interior concrete projects for other departments as requested
- Clean and organize forms
- Prepare and prioritize projects for upcoming season

### PROJECTS CREW:

- Snow removal, as weather dictates.
- Sign maintenance, site furniture, post and chain inspection
- Assist internal units, Utilities and other Shops as requested

**WASTE MANAGEMENT:**

- Snow removal, as weather dictates
- Garbage truck routes
- Litter receptacle routes
- Roll-off and compactor routes

**MECHANICS:**

- Snow removal, as weather dictates
- Service and repairs

**SUPERVISOR:**

- Snow Reports
- Monitor snow melt systems
- Planning and scheduling
- Monitor Compliance Training for self and staff
- AiM – Approve time entries, assign new work requests, close completed work requests
- Track warehouse stock data entry / equipment rental usage
- Performance appraisals
- Attend Shade Tree Short Course at Iowa State University
- RSVP to Iowa Urban Forestry Council for April Awards recognition for Tree Campus USA renewal
- Monitor progress of Winter Projects List
- Tree seedling operation in Micronursery
- Register for Continuing Instruction Course credits at Johnson County Extension for those needing Category 3OT

# LANDSCAPE SERVICES CALENDAR

## MARCH

### ALL STAFF:

- Monitor Compliance Training requirements
- Clean vehicles weekly

### AREA GROUNDSKEEPERS:

- Snow removal as weather dictates. Check for slippery areas on non-snow days
- Litter and debris removal
- Winter Projects List – tree work, prairie and savanna management
- Repair turf damage from snow removal operation along sidewalk margins
- Clean up sand from Winter snow removal operation
- Attend Continuing Instruction Course for Pesticide License requirements at Johnson County Extension office
- Do not apply pesticides on the Pentacrest until after the Easter Egg Hunt
- Cut back ornamental grass foliage
- Area 7: Return benches and planters to EMRB statue

### OAKDALE CAMPUS:

- Snow Removal as weather dictates. Check for slippery areas on non-snow days.
- Litter and debris Removal
- Winter Projects List – tree work
- Repair turf damage from snow removal operation along sidewalk margins

### TREE CREW:

- Snow removal as weather dictates. Assist Area Gk's w/ slippery areas as needed
- Winter Projects List – tree work, prairie and savanna management
- Tree inventory
- RSVP to annual Iowa Urban Tree Council awards banquet
- Organize Tree Campus USA Service Learning Projects w/ student groups
- Conduct prairie burns
- Perform tree work based on Tree Management Plan found in Tree Campus USA submittal

### TURF CREW:

- Assist Area Groundskeepers w/ restore turf damage from Winter snow removal operation
- Winter Projects List – tree work, prairie and savanna management
- Apply 1st of two applications of gypsum to sidewalk margins to leach salt from Winter operations
- Aerate turf
- Formalize mow routes for season
- Mow ornamental grasses on berm at Hawkeye Storage parking lot

### IRRIGATION SPECIALIST:

- Assist Area Gk's with monitoring slippery areas, as needed
- Winter Projects List - tree work, prairie and Savanna management
- Design of irrigation systems

### INSTALLATION CREW:

- Prepare planting beds

**CONCRETE CREW:**

- Prepare List of projects for the season
- Sidewalk repairs

**PROJECTS CREW:**

- Sign maintenance, site furniture, post and chain inspection
- Asphalt patching
- Assist internal units, Utilities and other Shops as requested

**WASTE MANAGEMENT:**

- Snow removal, as weather dictates
- Garbage truck routes
- Litter receptacle routes
- Roll-off and compactor routes

**MECHANICS:**

- Snow removal, as weather dictates
- Service and repairs. Inspect mowers for season.
- Convert Toro Polar Tracks to mowers

**SUPERVISOR:**

- Snow Reports
- Monitor snow melt systems
- Planning and scheduling
- Monitor Compliance Training for self and staff
- AiM – Approve time entries, assign new work requests, close completed work requests
- Track warehouse stock data entry / equipment rental usage
- Monitor progress of Winter Projects List
- Tree seedling operation in Micronursery
- Distribute Pesticide Log sheets to Groundkeeper II's, Arborist, and Tree Trimmers
- Notify stakeholders of prairie burns



# LANDSCAPE SERVICES CALENDAR

## APRIL

### ALL STAFF:

- Monitor Compliance Training requirements
- Clean vehicles weekly

### AREA GROUNDSKEEPERS:

- Litter and debris removal
- Repair turf damage from Winter snow removal operation along sidewalk margins
- Apply pre-emergent herbicide in mulched areas
- Apply 1st of five Holganix to turf in week 2.
- Follow program in Appendix.
- Do not apply pesticides to Pentacrest turf until after Easter Egg Hunt
- Bed maintenance
- Mulch tree rings. See diagram in Appendix.
- Area 8: ABW pond maintenance. See Appendix for details.

### OAKDALE CAMPUS:

- Litter and debris removal
- Repair turf damage from Winter snow removal operation along sidewalk margins
- Mow turf
- Apply pre-emergent herbicide in mulched areas
- Bed maintenance
- Mulch tree rings. See diagram in Appendix.

### TREE CREW:

- Attend annual Iowa Urban Forestry Council awards luncheon
- Tree inventory
- Perform tree work based on Tree Management Plan found in Tree Campus USA submittal
- Lead Service Learning Projects w/ student groups for Tree Campus USA requirements
- Install a tree on Arbor Day, raise Tree Campus USA flag over Old Capitol

### TURF CREW:

- Average date of first mowing of the Pentacrest is April 20
- Overseeding window is April 15 – May 31 for majority of projects
- Sod along selected sidewalk margins

### IRRIGATION SPECIALIST:

- Charge irrigation systems
- See Appendix

### INSTALLATION CREW:

- Bed preparation
- Greenhouse operation

### CONCRETE CREW:

- Sidewalk repairs

### PROJECTS CREW:

- Sign maintenance, site furniture, post and chain inspection
- Asphalt patching
- Assist internal units, Utilities and other Shops as requested

### WASTE MANAGEMENT:

- Garbage truck routes
- Litter receptacle routes
- Roll-off and compactor routes

### MECHANICS:

- Service and repairs

**SUPERVISOR:**

- Planning and scheduling
- Submit Quarterly Absence Log to FM – HR
- Monitor Compliance Training for self and staff
- AiM – Approve time entries, assign new work requests, close completed work requests
- Track warehouse stock data entry / equipment rental usage
- Tree seedling operation in Micronursery
- Request permission to raise Tree Campus USA flag over Old Capitol
- Set up area tours

# LANDSCAPE SERVICES CALENDAR

## MAY

### ALL STAFF:

- Monitor Compliance Training requirements
- Clean vehicles weekly

### AREA GROUNDSKEEPERS:

- Litter and debris removal
- Apply 2nd of five Holganix applications in week 3, after Commencement. Follow program in Appendix.
- Bed maintenance
- Mulch tree rings. See diagram in Appendix.
- Prune back daffodil foliage for esthetics
- Prune back deciduous shrubs such as Forsythia as necessary after the blooming period
- Area 5: Inspect BLB atria prior to the end of semester
- Area 8: ABW pond maintenance. See Appendix.

### OAKDALE CAMPUS:

- Litter and debris removal
- Mow turf
- Bed maintenance
- Mulch tree rings. See diagram in Appendix.

### TREE CREW:

- Tree inventory
- Perform tree work based on Tree Management Plan found in Tree Campus USA submittal
- Transfer seedlings from Micronursery to outdoor storage

### TURF CREW:

- Mow turf
- Overseeding window is April 15 – May 31 for majority of projects
- Sod along selected sidewalk margins

### IRRIGATION SPECIALIST:

- See Appendix for maintenance schedule

### INSTALLATION CREW:

- Install annuals

### CONCRETE CREW:

- Sidewalk repairs from prepared list

### PROJECTS CREW:

- Sign maintenance, site furniture, post and chain inspection
- Asphalt patching
- Assist internal units, Utilities and other Shops as requested
- Assist UI Housing w/ Move Out after end of semester

### WASTE MANAGEMENT CREWS:

- Garbage truck route
- Trash can route
- Roll-off and compactor routes
- Assist UI Housing w/ Move Out after end of Spring Semester

### SUPERVISOR:

- Planning and scheduling
- Monitor Compliance Training requirements for self and staff
- AiM: Approve time entries, assign new work requests, close completed work requests
- Track warehouse stock data entry / equipment rental usage

# LANDSCAPE SERVICES CALENDAR

## JUNE

### ALL STAFF:

- Monitor Compliance Training requirements
- Clean vehicles weekly

### AREA GROUNDSKEEPERS:

- Litter and debris removal
- Apply 3rd of five Holganix applications in week 3. Follow program in Appendix.
- Bed maintenance
- Mulch tree rings. See diagram in Appendix.
- Area 1: Prune back Dwarf Lilacs as needed after blooming period
- Area 8: ABW pond maintenance. See Appendix.

### OAKDALE CAMPUS:

- Litter and debris removal
- Mow turf
- Bed maintenance
- Mulch tree rings. See diagram in Appendix.

### TREE CREW:

- Tree inventory
- Perform tree work based on Tree Management Plan found in Tree Campus USA submittal

### TURF CREW:

- Mow turf

### IRRIGATION SPECIALIST:

- See Appendix

### INSTALLATION CREW:

- Monitor seasonal color beds and project work

### CONCRETE CREW:

- Sidewalk repairs from project list

### PROJECTS CREW:

- Sign maintenance, site furniture, post and chain inspection
- Asphalt patching
- Assist internal units, Utilities and other Shops as requested

### WASTE MANAGEMENT CREWS:

- Garbage truck route
- Litter receptacle route
- Roll-off and compactor routes

### MECHANICS:

- Service and repairs

### SUPERVISOR:

- Planning and scheduling
- Monitor Compliance Training requirements for self and staff
- Track warehouse stock data entry / equipment rental usage
- AiM: Approve time entries, assign new work requests, close completed work requests
- Set up area tours

# LANDSCAPE SERVICES CALENDAR

## JULY

### ALL STAFF:

- Monitor Compliance Training requirements
- Clean vehicles weekly

### AREA GROUNDSKEEPERS:

- Litter and debris removal
- Apply 4th of 5 Holganix applications in week 4.
- Follow program in Appendix.
- Bed maintenance
- Mulch tree rings. See diagram in Appendix.
- Area 8: ABW pond maintenance. See Appendix.
- Apply Pre-Emergent in mulched area
- Edge sidewalks

### OAKDALE CREW:

- Litter and debris removal
- Mow turf
- Bed maintenance
- Mulch tree rings. See diagram in Appendix
- Apply Pre-Emergent in mulched area

### TREE CREW:

- Tree inventory
- Perform tree work based on Tree Management
- Plan found in Tree Campus USA

### TURF CREW:

- Mow turf

### IRRIGATION SPECIALIST:

- See Appendix

### INSTALLATION CREW:

- Monitor seasonal color beds and project work

### CONCRETE CREW:

- Sidewalk repairs from project list

### PROJECTS CREW:

- Sign maintenance, site furniture, post and chain inspection
- Asphalt patching
- Assist internal units, Utilities and other Shops as requested

### WASTE MANAGEMENT CREWS:

- Garbage truck route
- Litter receptacle route
- Roll-off and compactor routes

### MECHANICS:

- Service and repairs

### SUPERVISOR:

- Submit Quarterly Absence Log to FM - HR
- Planning and scheduling
- Monitor Compliance Training requirements for self and staff
- Track warehouse stock data entry / equipment rental usage
- AiM: Approve time entries, assign new work requests, close completed work requests

# LANDSCAPE SERVICES CALENDAR

## AUGUST

### ALL STAFF:

- Monitor Compliance Training requirements
- Clean vehicles weekly

### AREA GROUNDSKEEPERS:

- Litter and debris removal
- Bed maintenance
- Mulch tree rings. See diagram in Appendix.
- Area 3: Prune Privet hedge at the President's residence prior to Convocation ceremony and Block Party.
- Area 8: ABW pond maintenance. See Appendix.

### OAKDALE CREW:

- Litter and Debris removal
- Mow turf
- Bed maintenance
- Mulch tree rings. See diagram in Appendix.

### TREE CREW:

- Tree inventory
- Perform tree work based on Tree Management plan found in Tree Campus USA submittal

### TURF CREW:

- Mow turf
- Overseeding window is August 15 – September 30 for majority of projects

### IRRIGATION SPECIALIST:

- See Appendix

### INSTALLATION CREW:

- Monitor seasonal color beds and project work

### CONCRETE CREW:

- Sidewalk repairs from project list

### PROJECTS CREW:

- Sign maintenance, site furniture, post and chain inspection
- Asphalt patching
- Assist internal units, Utilities and other Shops as requested
- Assist UI Housing during Move In

### WASTE MANAGEMENT CREWS:

- Garbage truck route
- Litter receptacle route
- Roll-off and compactor routes

### MECHANICS:

- Service and repairs

### SUPERVISOR:

- Planning and scheduling
- Monitor Compliance Training requirements for self and staff
- Track warehouse stock data entry / equipment rental usage
- AiM: Approve time entries, assign new work requests, close completed work requests
- Set up area tours

# LANDSCAPE SERVICES CALENDAR

## SEPTEMBER

### ALL STAFF:

- Monitor Compliance Training requirements
- Clean vehicles weekly

### AREA GROUNDSKEEPERS:

- Litter and debris removal
- Apply 5th of five Holganix applications in week 1. Follow program in Appendix.
- Bed maintenance
- Leaf removal
- Mulch tree rings. See diagram in Appendix.
- Area 8: ABW pond maintenance. See Appendix.

### OAKDALE CREW:

- Litter and debris removal
- Mow turf
- Bed maintenance
- Leaf removal
- Mulch tree rings. See diagram in Appendix.

### TREE CREW:

- Tree inventory
- Perform tree work based on Tree Management Plan found in Tree Campus USA submittal
- Collect seeds from selected trees on campus and from other contacts

### TURF CREW:

- Mow turf
- Overseeding window is August 15 – September 30 for majority of projects
- Urea Application

### IRRIGATION SPECIALIST:

- See Appendix

### INSTALLATION CREW:

- Monitor seasonal color beds and project work

### CONCRETE CREW:

- Sidewalk repairs from prepared list

### PROJECTS CREW:

- Sign maintenance, site furniture, post and chain inspection
- Asphalt patching
- Assist internal units, Utilities and other Shops as requested

### WASTE MANAGEMENT CREWS:

- Garbage truck route
- Litter receptacle route
- Roll-off and compactor routes

### MECHANICS:

- Service and repairs

### SUPERVISOR:

- Planning and scheduling
- Monitor Compliance Training requirements for self and staff
- Track warehouse stock data entry / equipment rental usage
- AiM: Approve time entries, assign new work requests, close completed work requests

# LANDSCAPE SERVICES CALENDAR

## OCTOBER

### ALL STAFF:

- Monitor Compliance Training requirements
- Clean vehicles weekly

### AREA GROUNDSKEEPERS:

- Litter and debris removal
- Bed maintenance
- Leaf removal
- Mulch tree rings. See diagram in Appendix.
- Area 8: ABW pond maintenance. See Appendix.

### OAKALE CREW:

- Litter and debris removal
- Mow turf
- Bed maintenance
- Leaf removal
- Mulch tree rings. See diagram in Appendix.

### TREE CREW:

- Tree inventory
- Perform tree work based on Tree Management plan found in Tree Campus USA submittal
- Collect seeds from selected campus trees and from other contacts

### TURF CREW:

- Mow turf
- Apply 2nd of two applications of gypsum to sidewalk margins to counteract salt from Winter operation
- Aerate turf in Service Level A areas
- Perform Irrigation checks

### IRRIGATION SPECIALIST:

- See Appendix

### INSTALLATION CREW:

- Monitor seasonal color beds and project work
- Install Mums in selected areas

- Retrieve vertical wall plantings and tender perennials and transport to Oakdale Greenhouse

### CONCRETE CREW:

- Sidewalk repairs from prepared list

### PROJECTS CREW:

- Sign maintenance, site furniture, post and chain inspection
- Asphalt patching
- Assist internal units, Utilities and other Shops as requested

### WASTE MANAGEMENT CREWS:

- Garbage truck route
- Litter receptacle route
- Roll-off and compactor routes

### MECHANICS:

- Service and repairs

### SUPERVISOR:

- Submit Quarterly Absence Log to FM – HR
- Planning and scheduling
- Monitor Compliance Training requirements for self
- AiM: Approve time entries, assign new work requests, close completed work requests
- Track warehouse stock and equipment rental
- Set up area tours



# LANDSCAPE SERVICES CALENDAR

## NOVEMBER

### ALL STAFF:

- Monitor Compliance Training requirements
- Clean vehicles weekly

### AREA GROUNDSKEEPERS:

- Litter and debris removal
- Bed maintenance
- Leaf removal
- Apply urea to turf
- Mulch tree rings. See diagram in Appendix.
- Area 7: Remove benches and planters from EMRB statue area

### OAKDALE CREW:

- Litter and debris removal
- Mow turf and fallen leaves
- Bed maintenance
- Leaf removal
- Apply urea to turf
- Mulch tree rings. See diagram in Appendix.

### TREE CREW:

- Tree inventory
- Perform tree work based on Tree Management plan found in Tree Campus USA submittal

### TURF CREW:

- Mow turf and fallen leaves
- Assist w/ leaf removal

### IRRIGATION SPECIALIST:

- Blow out Irrigation lines at the Pentacrest, Hubbard Park, PBDB, SC roof, President's Residence during Thanksgiving week

### INSTALLATION CREW:

- Remove annuals from beds
- Monitor Mums
- Transport tender perennials and vertical wall plantings to Oakdale greenhouse

### CONCRETE CREW:

- Sidewalk repairs from prepared list

### PROJECTS CREW:

- Sign maintenance, site furniture, post and chain inspection
- Asphalt patching
- Assist internal units, Utilities and other Shops as requested

### WASTE MANAGEMENT CREWS:

- Snow removal as weather dictates
- Garbage truck route
- Litter receptacle route
- Roll-off and Compactor routes

### MECHANICS:

- Service and repairs
- Convert Toro mowers to Polar Tracks

### SUPERVISOR:

- Discuss snow operation plans for the upcoming season
- Monitor snow melt systems
- Planning and scheduling
- Monitor Compliance Training for self
- AiM: Approve time entries, assign new work requests, close completed work requests
- Schedule Continuing Instruction Course credits for licensed applicators in categories for Aquatics, Greenhouse, Forestry, and anyone still needing Ornamental and Turf
- Track warehouse stock and equipment rental

# LANDSCAPE SERVICES CALENDAR

## DECEMBER

### ALL STAFF:

- Monitor Compliance Training requirements
- Clean vehicles weekly

### AREA GROUNDSKEEPERS:

- Snow removal as weather dictates. Check for slippery areas each morning on non-snow days.
- Litter and debris removal
- Winter Projects List – tree work, prairie and savanna management
- Complete CIC requirements for IDALS, including Greenhouse, Forestry, and Aquatics categories for appropriate staff

### OAKDALE CREW:

- Snow removal as weather dictates. Check for slippery areas each morning on non-snow days.
- Litter and debris removal
- Winter Projects List – tree work

### TREE CREW:

- Snow removal as weather dictates. Assist Area Groundskeepers w/ slippery areas, as needed.
- Tree inventory
- Tree work based on Tree Management plan in Appendix
- Winter Projects List – tree work, prairie and savanna management

### TURF CREW:

- Snow removal as weather dictates. Assist Area Groundskeepers w/ slippery areas, as needed.
- Winter Projects List – tree work, prairie and savanna management

### IRRIGATION SPECIALIST:

- See Appendix
- Snow removal as weather dictates.

### INSTALLATION CREW:

- Snow removal as weather dictates. Assist Area Groundskeepers w/ slippery areas, as needed.
- Greenhouse work for Spring installations – annuals, tender perennials, vertical walls, etc.

### CONCRETE CREW:

- Snow removal as weather dictates.
- Interior sidewalk projects for Building Maintenance
- Clean forms

### PROJECTS CREW:

- Snow removal as weather dictates
- Sign maintenance, site furniture, post and chain inspection
- Assist internal units, Utilities and other Shops as requested

### WASTE MANAGEMENT CREWS:

- Snow removal as weather dictates
- Garbage truck route
- Litter receptacle route
- Roll-off and compactor routes







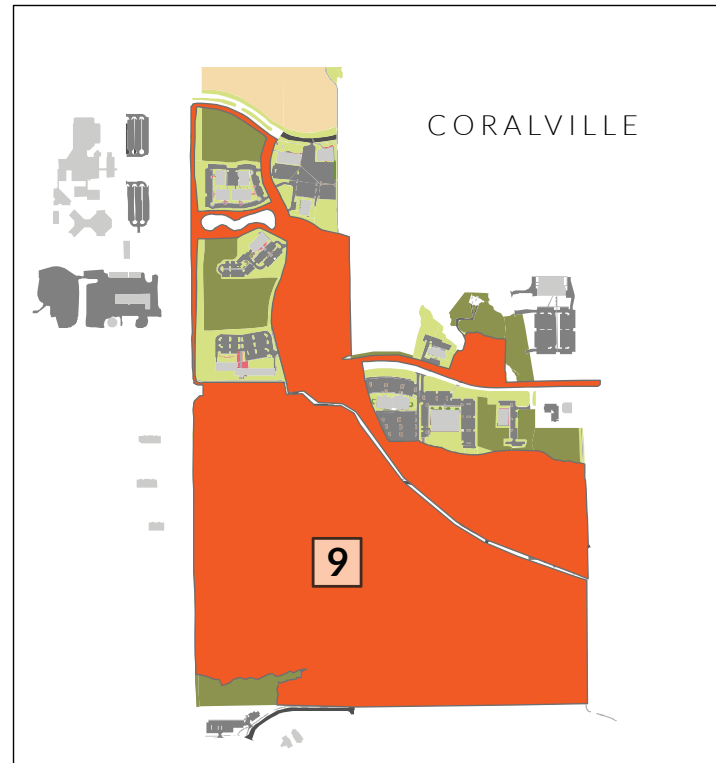

### MECHANICS:

- Service and repairs
- Snow removal as weather dictates

### SUPERVISOR:

- Snow Reports
- Monitor snow melt systems
- Planning and scheduling
- Monitor Compliance Training requirements for self and staff
- AiM – Approve time entries, assign new work requests, close completed work requests
- Performance Appraisals
- Monitor progress of Winter Projects List
- Establish new Safety Team for upcoming calendar year
- Retrieve Pesticide Log sheets from licensed applicators and file in notebook.
- Track warehouse stock and equipment rental



- MAINTENANCE AREA:
- 1 
  - 2 
  - 3 
  - 4 
  - 5 
  - 6 
  - 7 
  - 8 
  - 9 





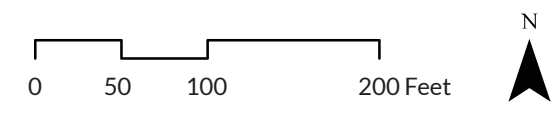
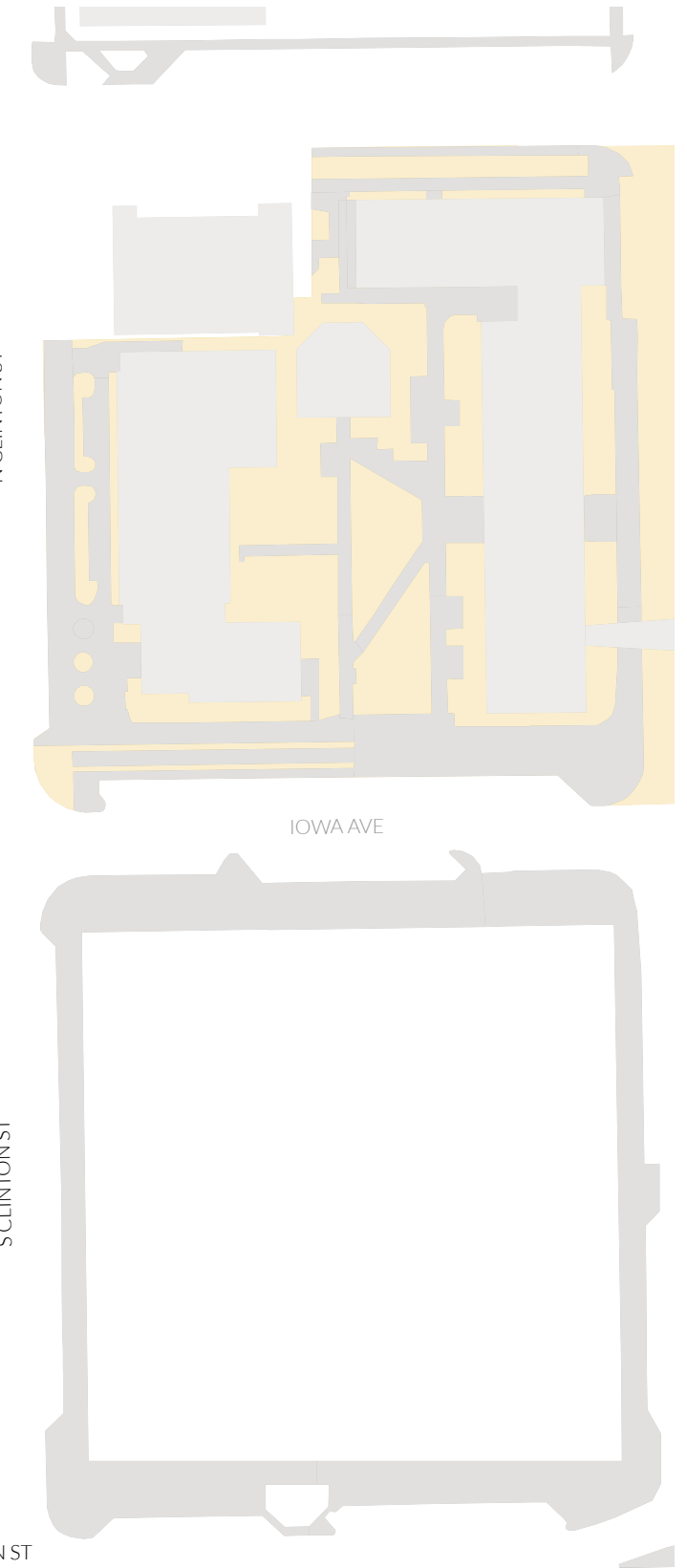
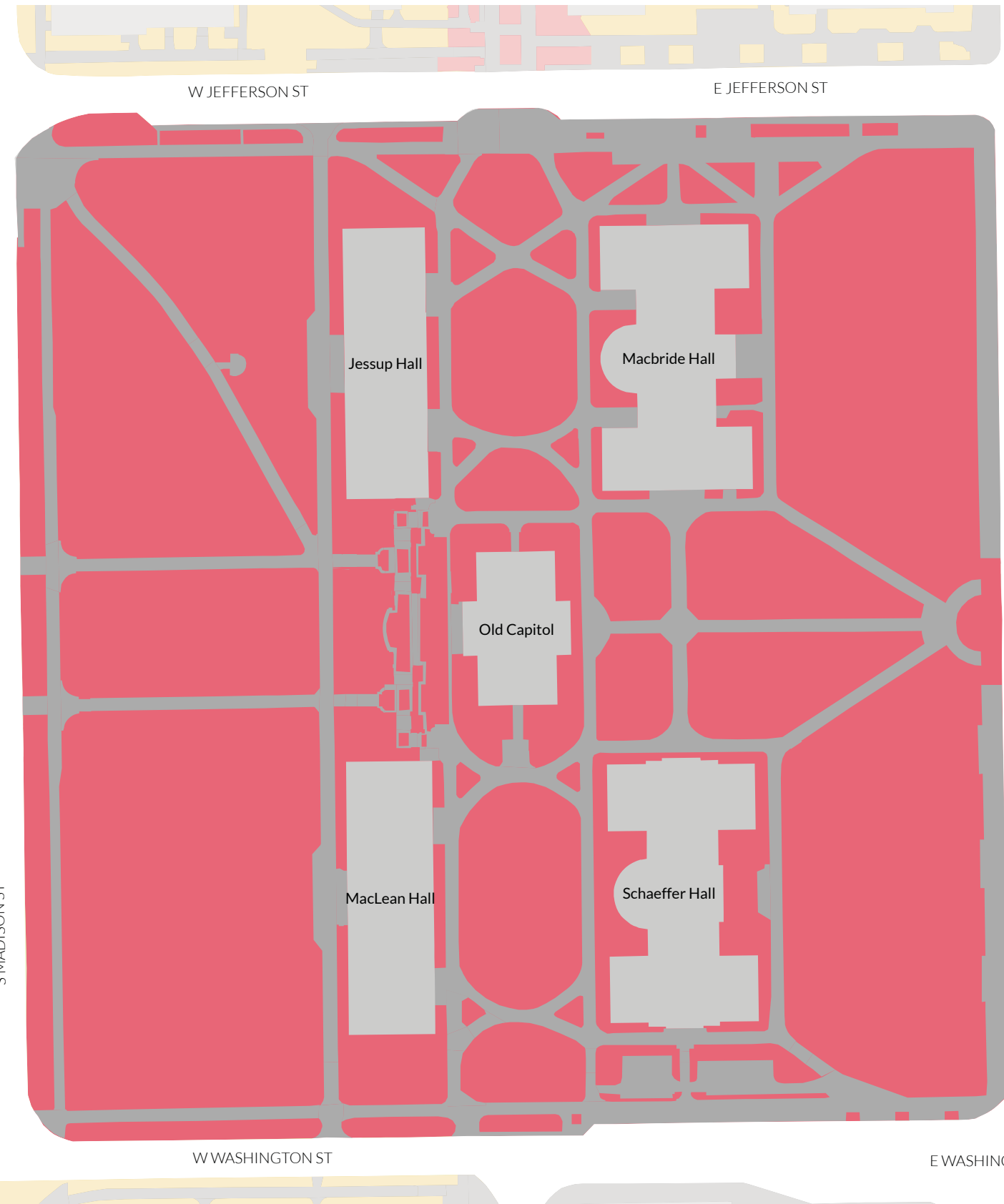
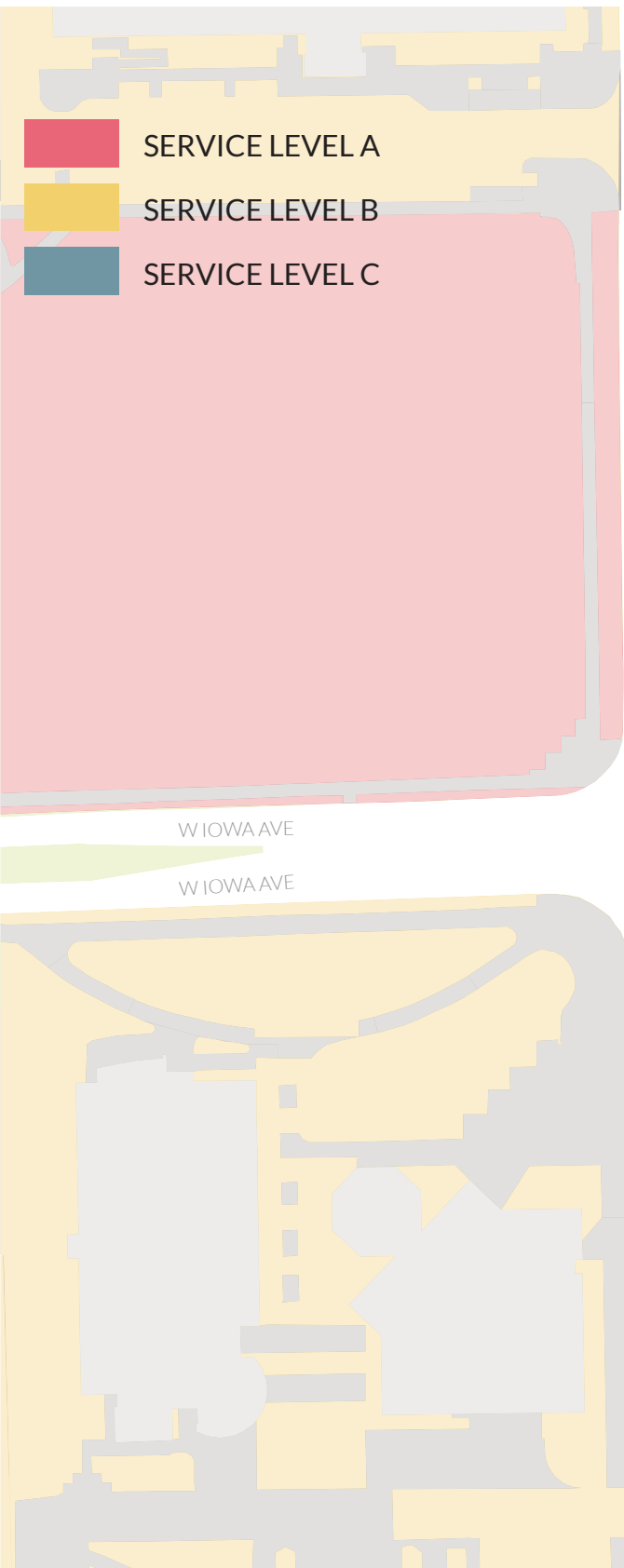

**MAINTENANCE AREA 1**

**LEGEND & MAINTENANCE PLAN**

	Total Sq Ft
University Buildings	
BLS Under Construction	
<b>Hardscape Improvements</b>	
Concrete	136,950.97
Colored concrete	
Granite pavers	5,978.58
Pavers	870.76
Parking lots	0
Institutional roads	10,983.00
Institutional roads (minor)	
<b>Landscape Improvements</b>	
Turf (traditional lawns)	365,783.65
Low/No Mow Areas	0
Prairie	0
Perennial Beds	4,316.35
Annual Beds	0
Groundcover Beds	3,506.94
Planters	0
Shrubs	12,718.75
Hedges	1,776.07
Mulched area	29,199.55
Wooded areas	0
Roof Garden Areas	0

**TOTAL** 572,084.63

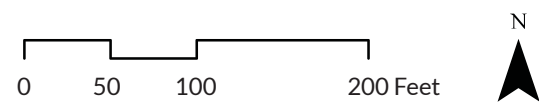
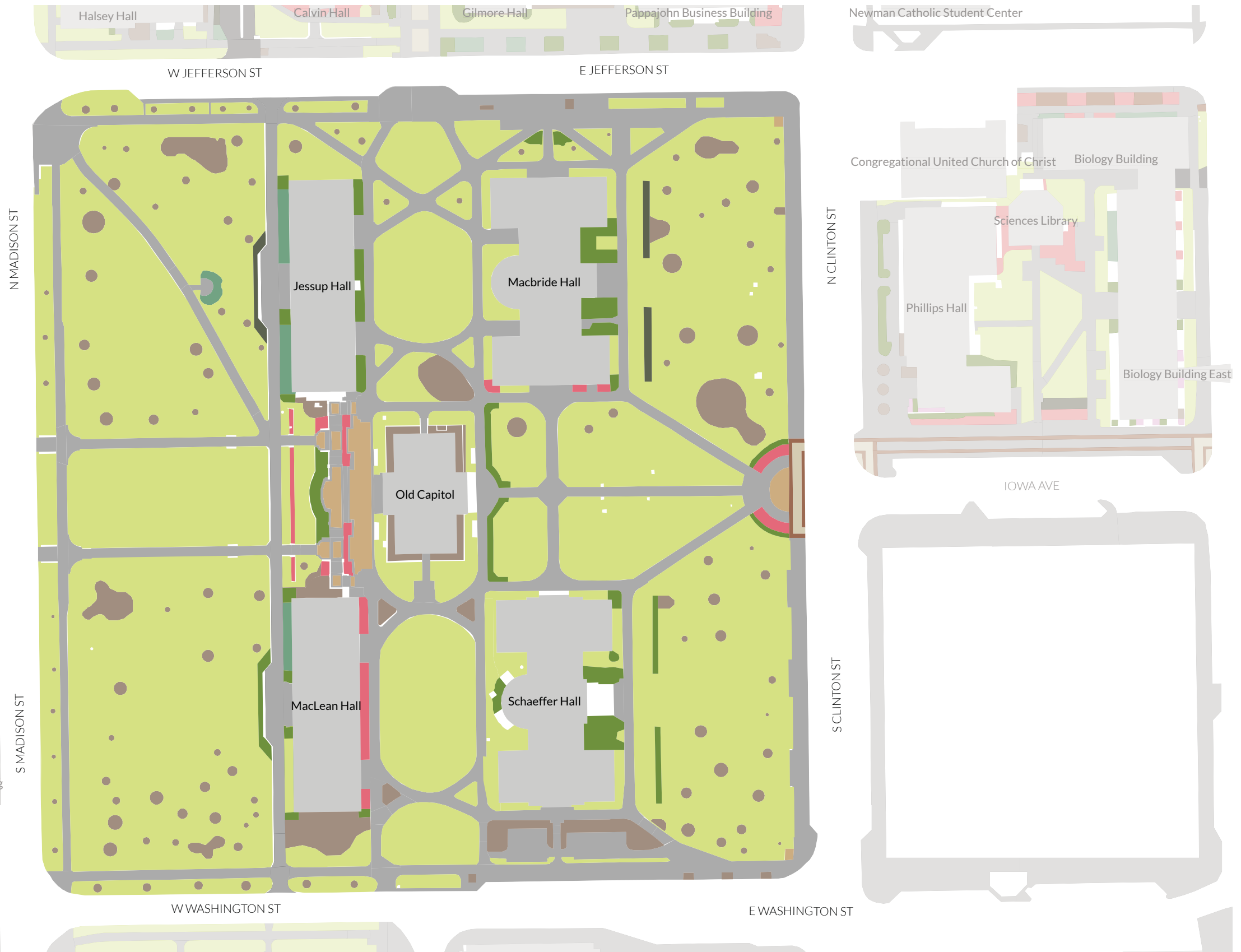

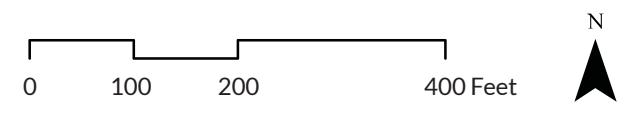
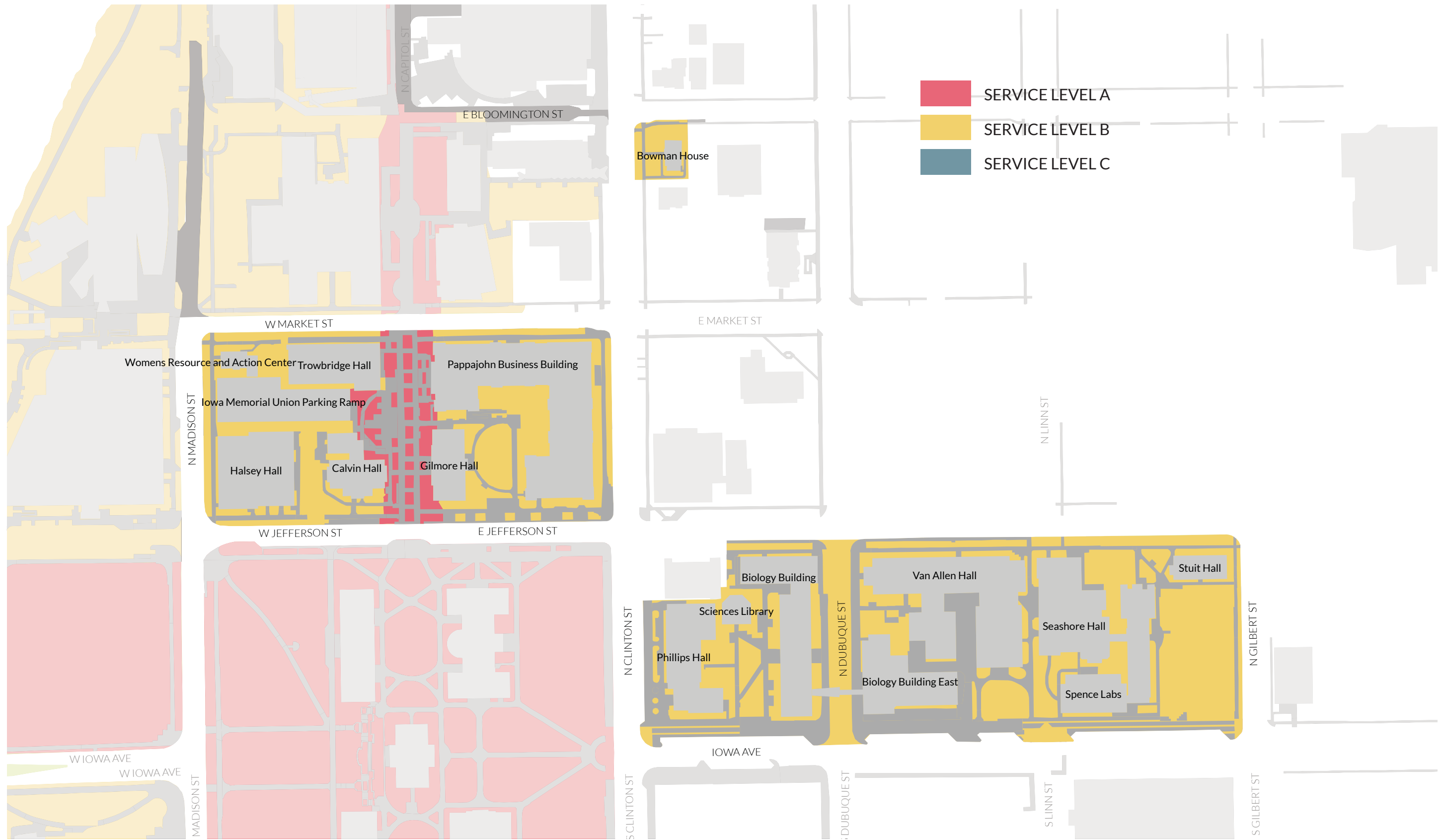

**MAINTENANCE AREA 2**

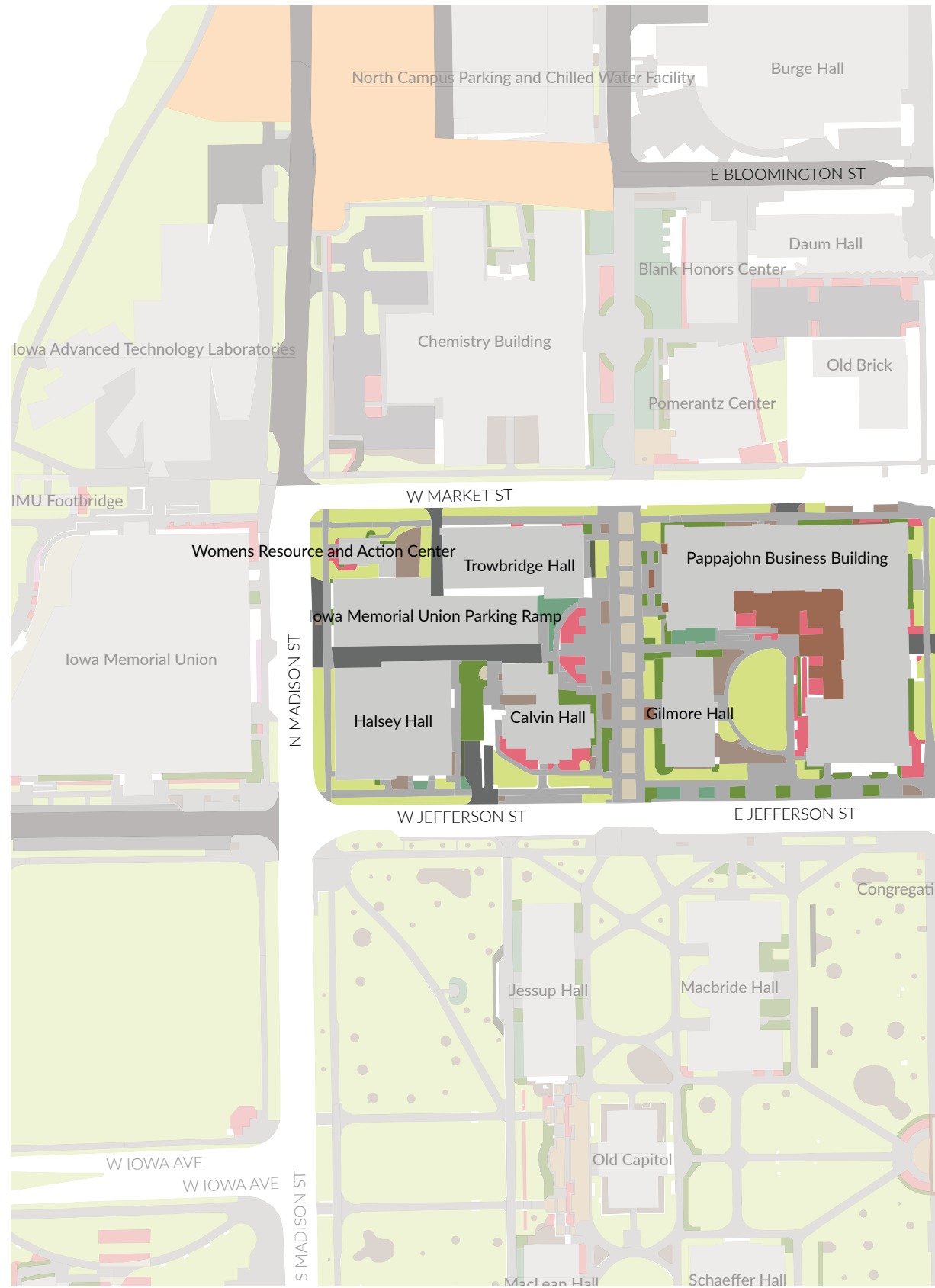

**LEGEND & MAINTENANCE PLAN**

University Buildings		Total Sq Ft
University Buildings		
BLS Under Construction		
<b>Hardscape Improvements</b>		
Concrete	198,808.73	
Colored concrete	0	
Granite pavers	0	
Pavers	8,257.65	
Parking lots	66,069.27	
Institutional roads	14,192.10	
Institutional roads (minor)	0	
<b>Landscape Improvements</b>		
Turf (traditional lawns)	103,276.71	
Low/No Mow Areas	0	
Prairie	0	
Perennial Beds	25,916.19	
Annual Beds	433.52	
Groundcover Beds	5,655.41	
Planters	0	
Shrubs	18,935.88	
Hedges	1,111.77	
Mulched area	12,086.89	
Wooded areas	0	
Roof Garden Areas	0	

**TOTAL** 454,744.12

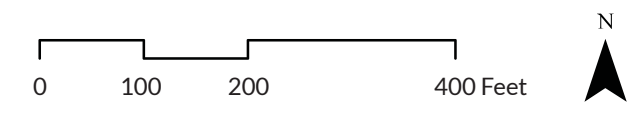



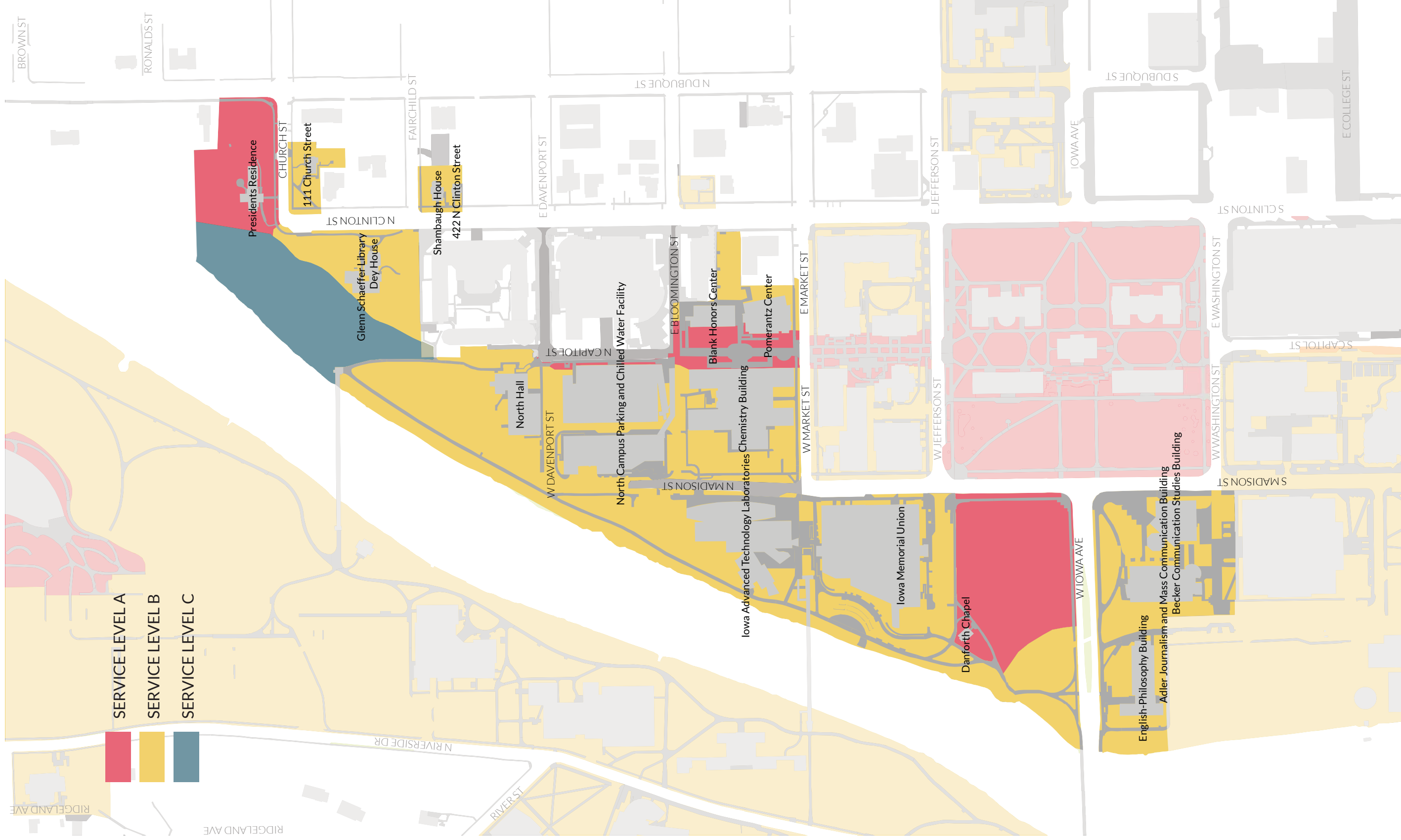

SERVICE LEVEL A  
 SERVICE LEVEL B  
 SERVICE LEVEL C



**MAINTENANCE AREA 3**

LEGEND & MAINTENANCE PLAN		Total Sq Ft
	University Buildings	
	BLS Under Construction	
<b>Hardscape Improvements</b>		
	Concrete	275,081.36
	Colored concrete	
	Granite pavers	1,773,442
	Pavers	15,182,711
	Parking lots	146,745.43
	Institutional roads	
	Institutional roads (minor)	92,562.52
<b>Landscape Improvements</b>		
	Turf (traditional lawns)	722,880.26
	Low/No Mow Areas	0
	Prairie	0
	Perennial Beds	25,950.22
	Annual Beds	1,101.42
	Groundcover Beds	19,433.14
	Planters	0
	Shrubs	18,108.66
	Hedges	6,023.20
	Mulched area	57,219.15
	Wooded areas	124,193.62
	Roof Garden Areas	0
<b>TOTAL</b>		<b>1,506,255.11</b>

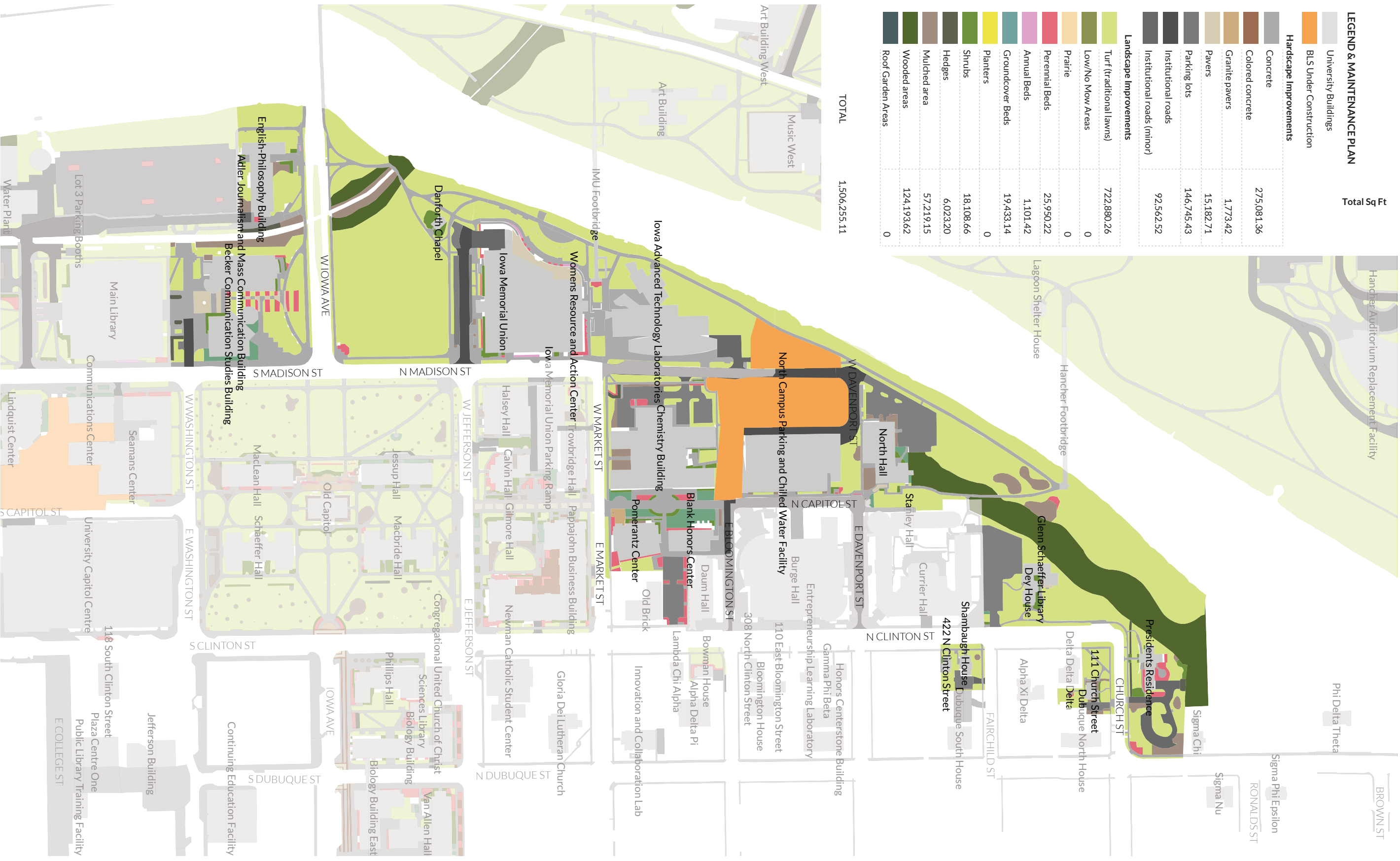

**MAINTENANCE AREA 3**

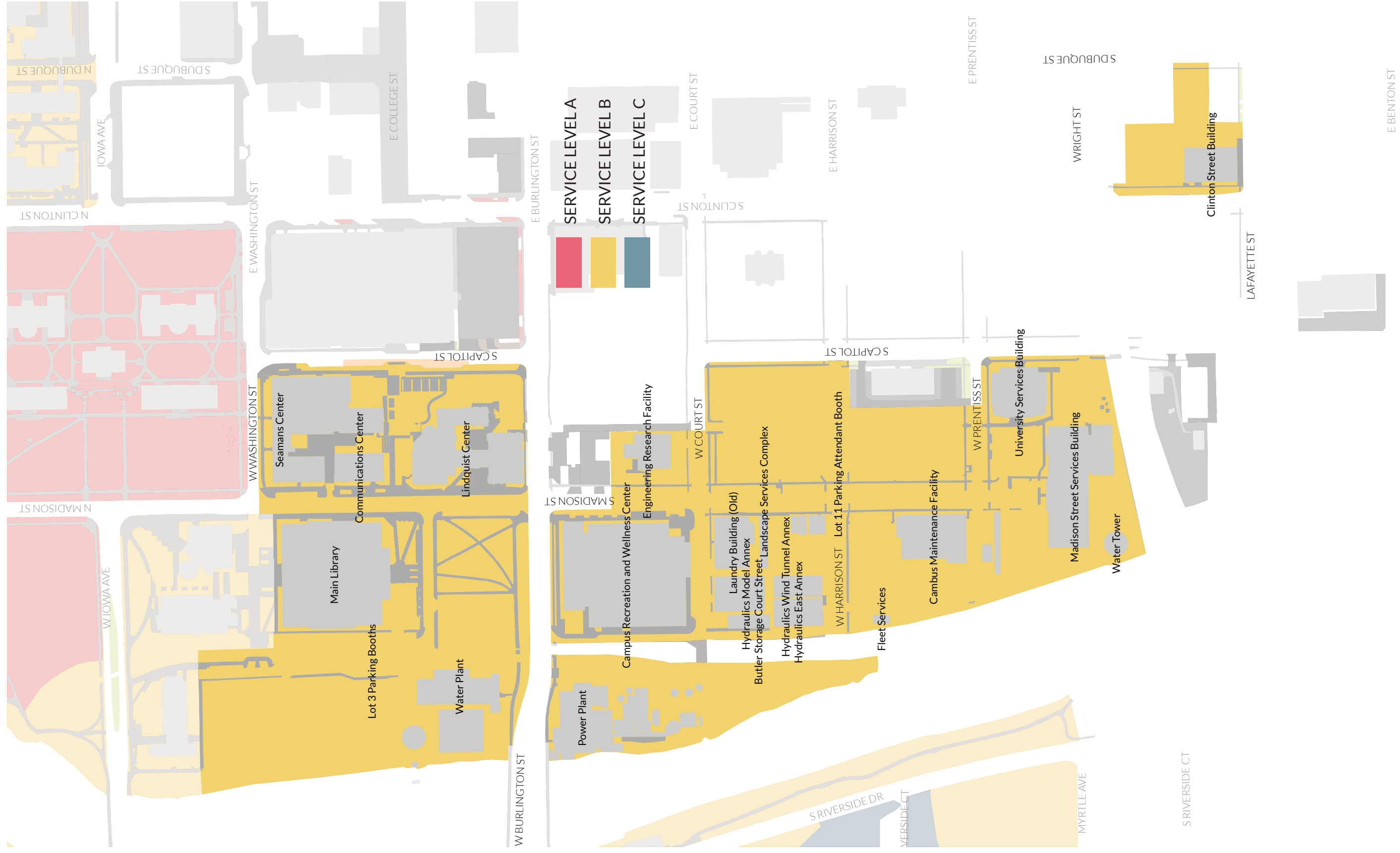

**MAINTENANCE AREA 4**



LEGEND & MAINTENANCE PLAN		Total Sq Ft
University Buildings		
BLS Under Construction		
<b>Hardscape Improvements</b>		
Concrete		208,418.88
Colored concrete		0
Granite pavers		6,253.75
Pavers		524,260.95
Parking lots		322,778.47
Institutional roads		
Institutional roads (minor)		
<b>Landscape Improvements</b>		
Turf (traditional lawns)		320,579.46
Low/No Mow Areas		0
Prairie		0
Perennial Beds		29,822.25
Annual Beds		800.34
Groundcover Beds		14,625.39
Planters		0
Shrubs		15,171.57
Hedges		5,385.56
Mulched area		25,426.69
Wooded areas		3,584.99
Roof Garden Areas		4,114.12
<b>TOTAL</b>		<b>1,481,222.42</b>

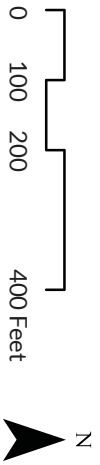

**MAINTENANCE AREA 4**

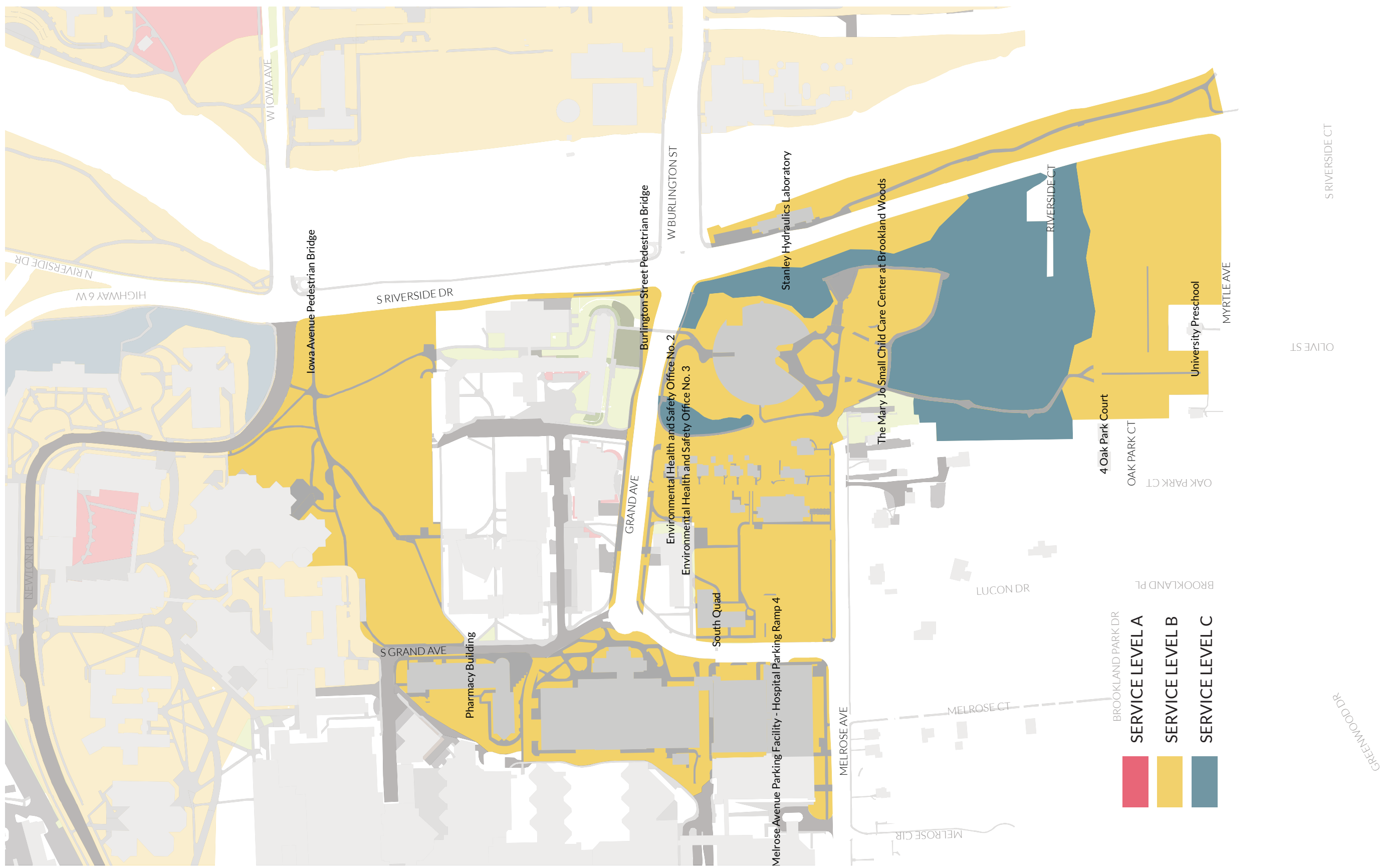

- SERVICE LEVEL A
- SERVICE LEVEL B
- SERVICE LEVEL C

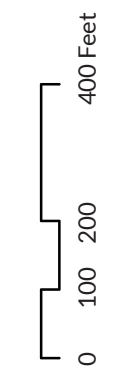



**LEGEND & MAINTENANCE PLAN**

University Buildings		Total Sq Ft
Concrete	205,016.70	
Colored concrete	0	
Granite pavers	765.84	
Pavers	305,945.64	
Parking lots	85,114.53	
Institutional roads		
Institutional roads (minor)		
Landscape Improvements		
Turf (traditional lawns)	623,225.95	
Low/No Mow Areas	0	
Prairie	0	
Perennial Beds	39,396.58	
Annual Beds	1,414.06	
Groundcover Beds	2,443.95	
Planters	0	
Shrubs	12,370.13	
Hedges	0	
Mulched area	21,458.22	
Wooded areas	602,235.42	
Roof Garden Areas	0	
<b>TOTAL</b>	<b>1,899,387.02</b>	



**MAINTENANCE AREA 5**

- SERVICE LEVEL A
- SERVICE LEVEL B
- SERVICE LEVEL C

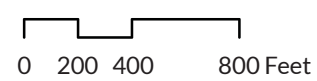
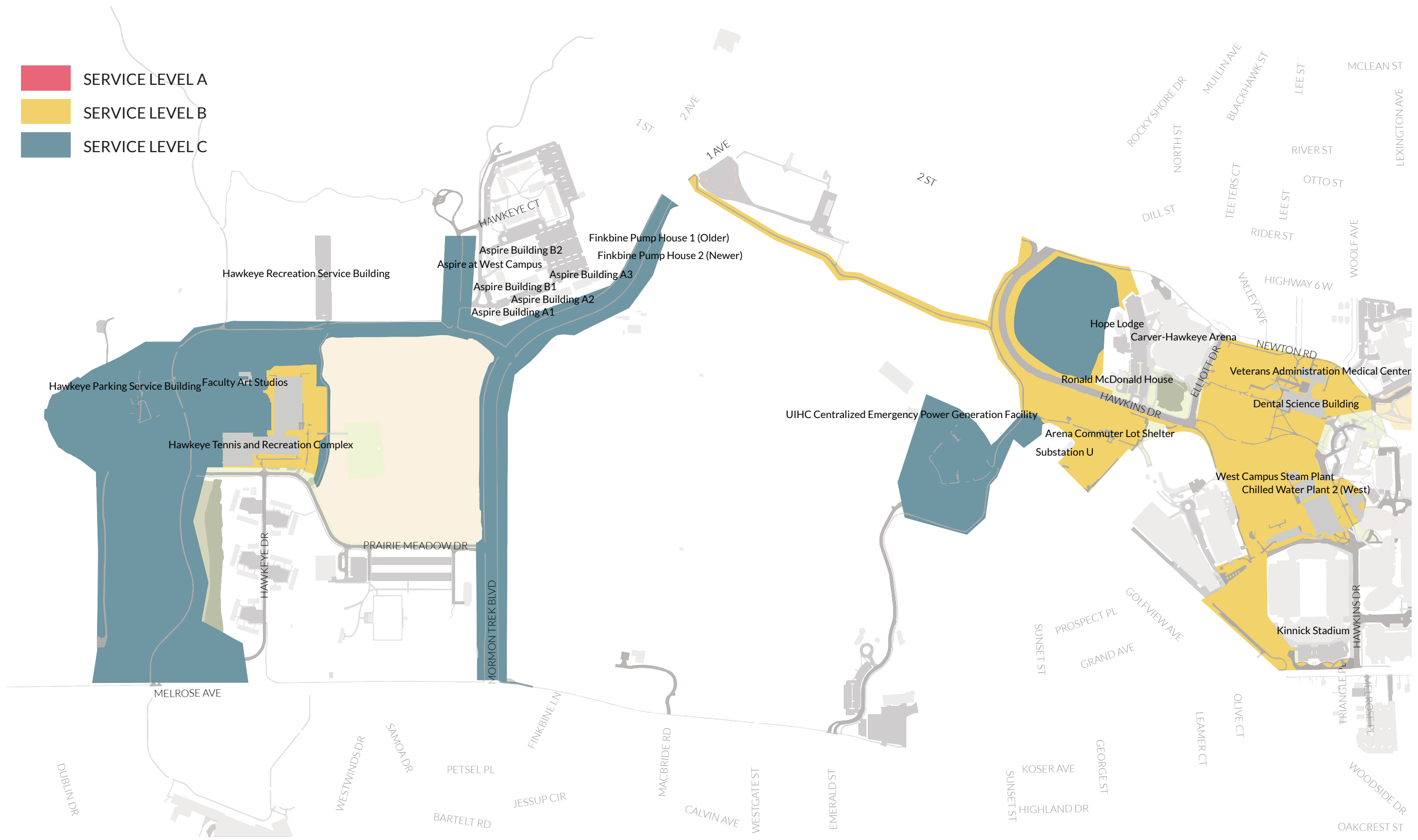

**MAINTENANCE AREA 6**

**LEGEND & MAINTENANCE PLAN**

	Total Sq Ft
University Buildings	
BLS Under Construction	
<b>Hardscape Improvements</b>	
Concrete	400,247.85
Colored concrete	
Granite pavers	0
Pavers	7,693.64
Parking lots	2,061,872.92
Institutional roads	695,515.08
Institutional roads (minor)	
<b>Landscape Improvements</b>	
Turf (traditional lawns)	2,324,093.06
Low/No Mow Areas	1,220,585.88
Prairie	361,279.59
Perennial Beds	63,939.21
Annual Beds	43,439.46
Groundcover Beds	1,947.56
Planters	307.51
Shrubs	24,970.53
Hedges	0
Mulched area	29,056.51
Wooded areas	780,252.87
Roof Garden Areas	0
<b>TOTAL</b>	<b>8,015,201.65</b>

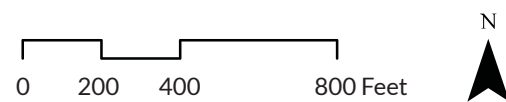
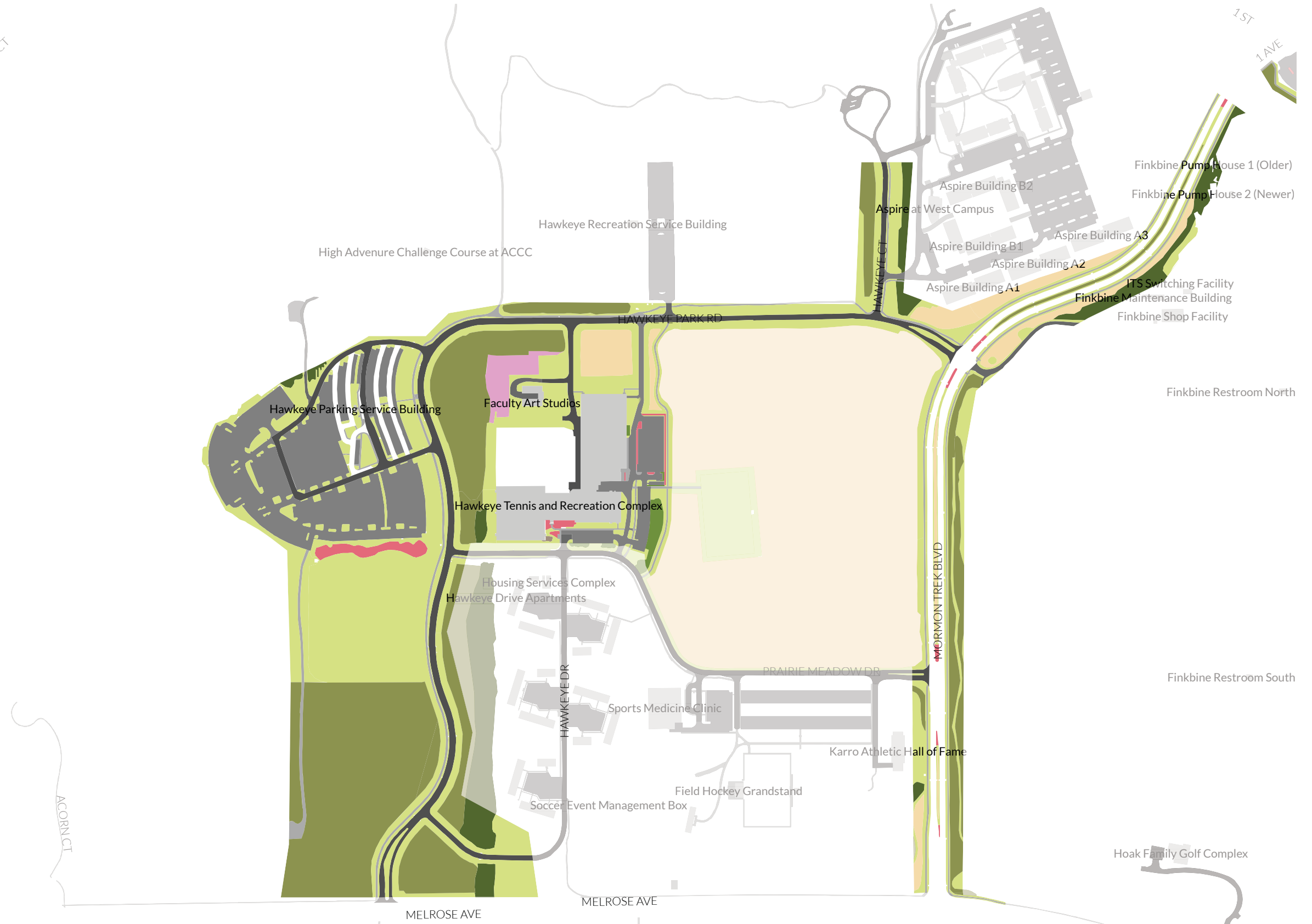



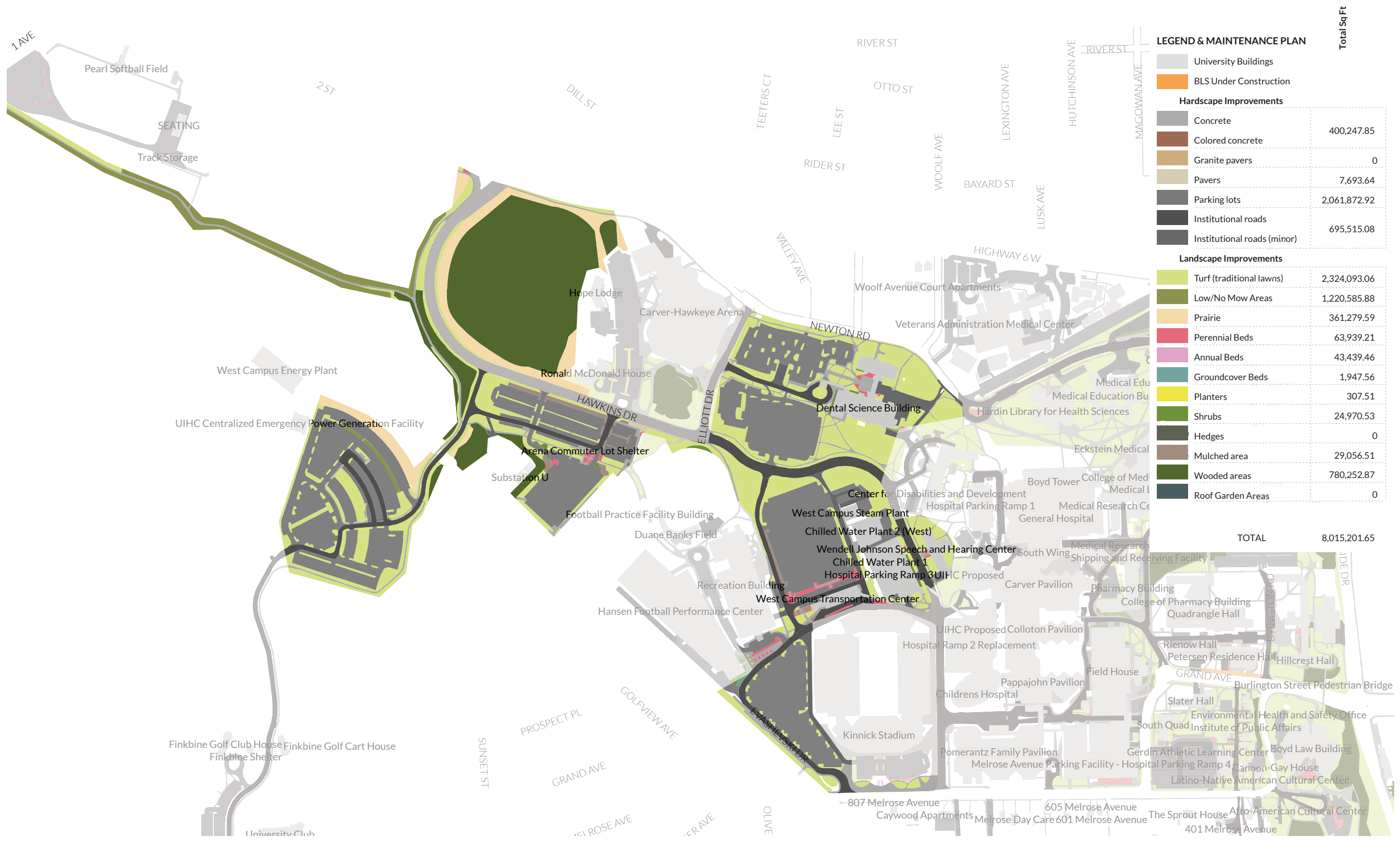

**LEGEND & MAINTENANCE PLAN**

Hardscape Improvements		Total Sq Ft
Concrete	400,247.85	
Colored concrete	0	
Granite pavers	7,693.64	
Pavers	2,061,872.92	
Parking lots	695,515.08	
Institutional roads		
Institutional roads (minor)		
Landscape Improvements		Total Sq Ft
Turf (traditional lawns)	2,324,093.06	
Low/No Mow Areas	1,220,585.88	
Prairie	361,279.59	
Perennial Beds	63,939.21	
Annual Beds	43,439.46	
Groundcover Beds	1,947.56	
Planters	307.51	
Shrubs	24,970.53	
Hedges	0	
Mulched area	29,056.51	
Wooded areas	780,252.87	
Roof Garden Areas	0	

**TOTAL 8,015,201.65**

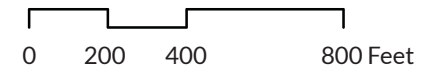

**MAINTENANCE AREA 6.2**



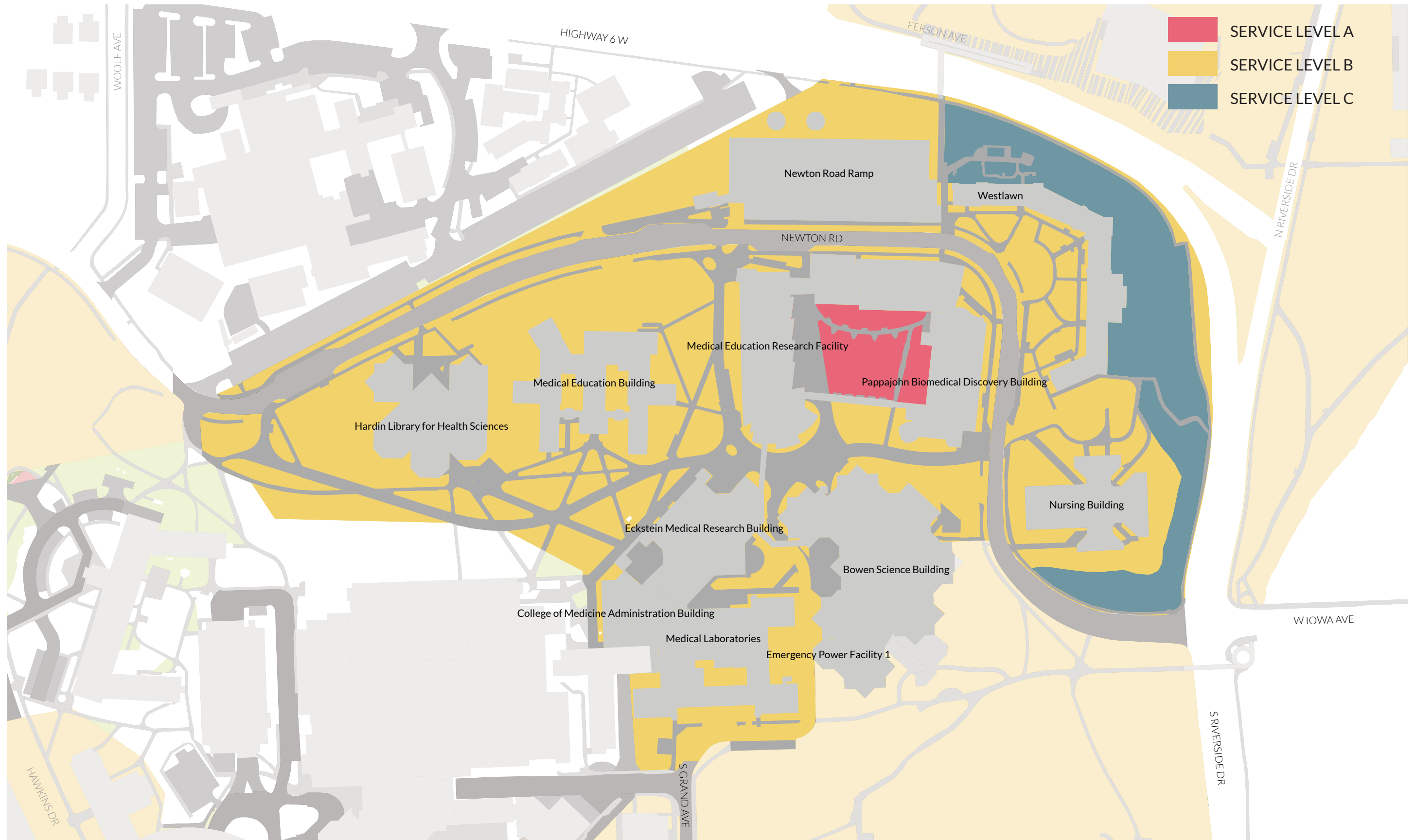

- SERVICE LEVEL A
- SERVICE LEVEL B
- SERVICE LEVEL C

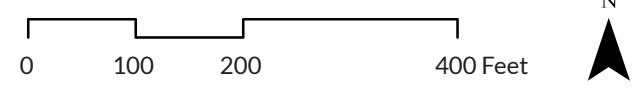

**MAINTENANCE AREA 7**

**LEGEND & MAINTENANCE PLAN**

	Total Sq Ft
University Buildings	
BLS Under Construction	
<b>Hardscape Improvements</b>	
Concrete	255,115.13
Colored concrete	0
Granite pavers	0
Pavers	5,802.88
Parking lots	75,414.77
Institutional roads	99,548.04
Institutional roads (minor)	
<b>Landscape Improvements</b>	
Turf (traditional lawns)	439,471.70
Low/No Mow Areas	0
Prairie	0
Perennial Beds	35,869.91
Annual Beds	507.23
Groundcover Beds	3,877.38
Planters	0
Shrubs	9,542.60
Hedges	0
Mulched area	12,235.39
Wooded areas	47,530.92
Roof Garden Areas	6,619.12

TOTAL 991,535.07

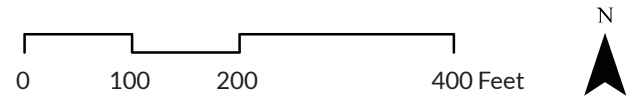
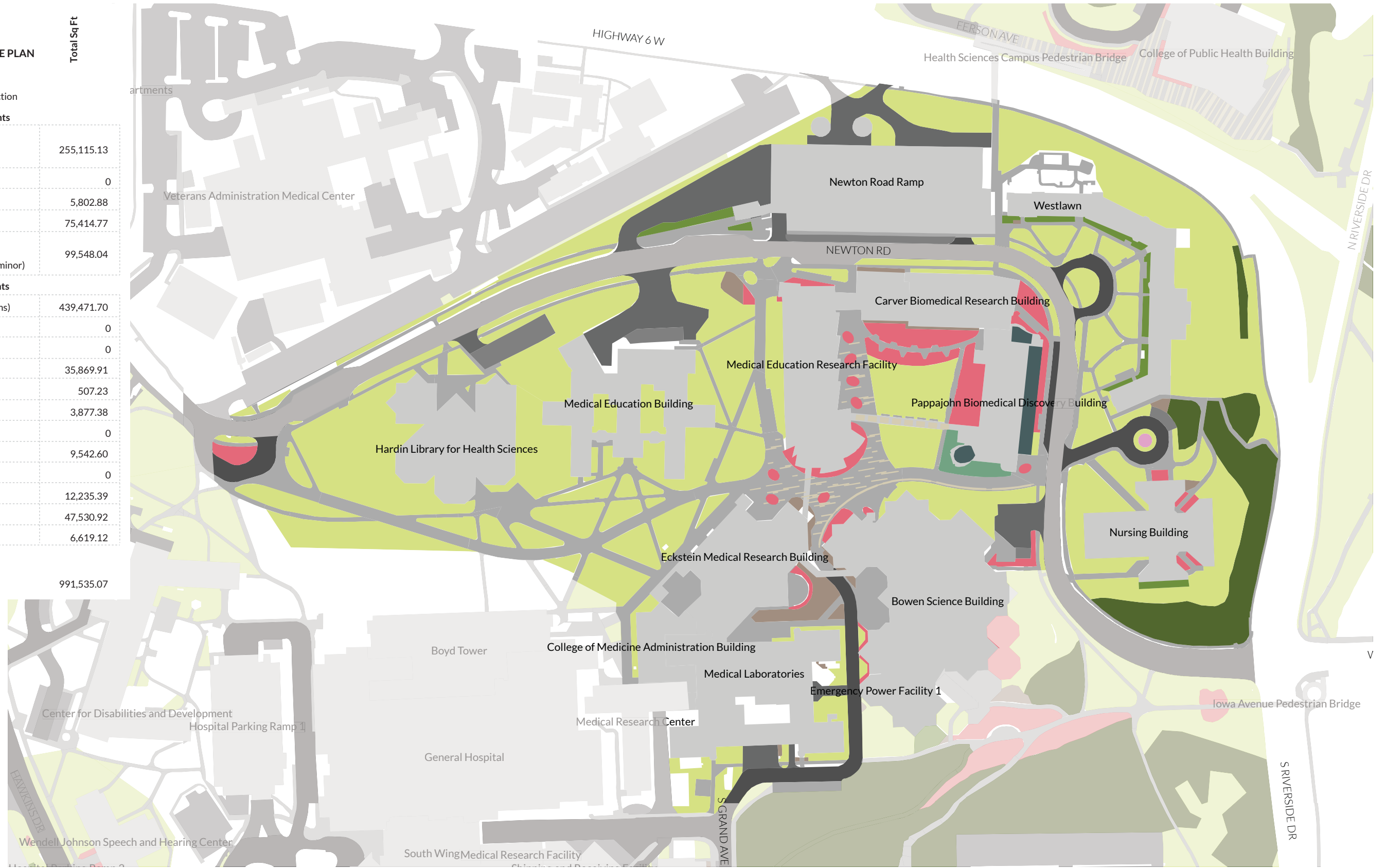

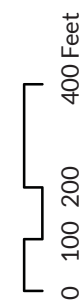
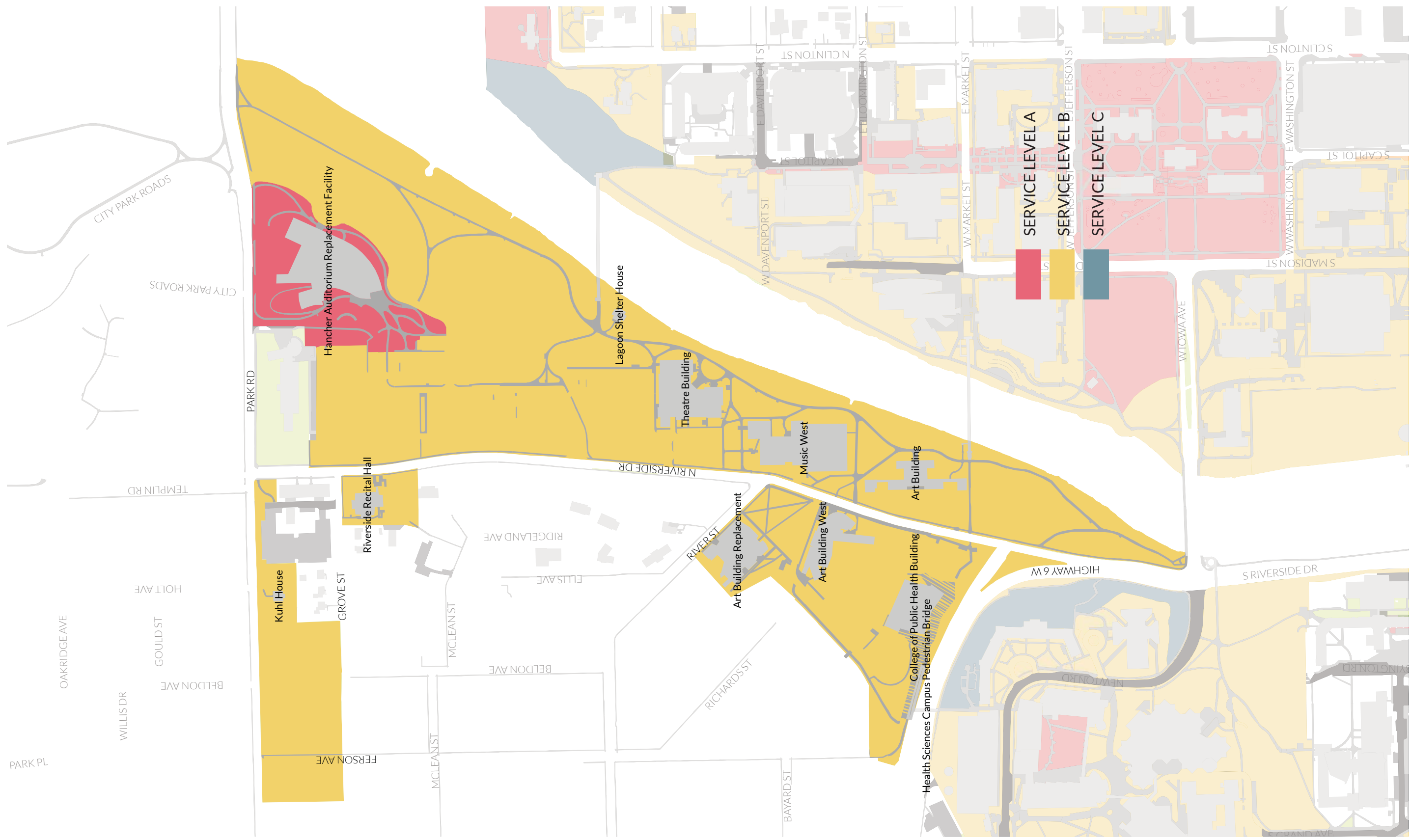

**MAINTENANCE AREA 8**



**LEGEND & MAINTENANCE PLAN**

Total Sq Ft

University Buildings	
BLS Under Construction	
<b>Hardscape Improvements</b>	
Concrete	261,454.10
Colored concrete	
Granite pavers	0
Pavers	15,660.11
Parking lots	332,839.99
Institutional roads	
Institutional roads (minor)	222,185.52
<b>Landscape Improvements</b>	
Turf (traditional lawns)	1,874,878.30
Low/No Mow Areas	0
Prairie	0
Perennial Beds	54,903.84
Annual Beds	0
Groundcover Beds	21,923.1
Planters	21,683.02
Shrubs	14,523.27
Hedges	0
Mulched area	14,359.81
Wooded areas	81,018.47
Roof Garden Areas	15,781.25
<b>TOTAL</b>	<b>2,909,549.43</b>

**MAINTENANCE AREA 8**



- SERVICE LEVEL A
- SERVICE LEVEL B
- SERVICE LEVEL C

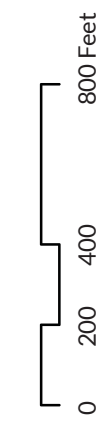

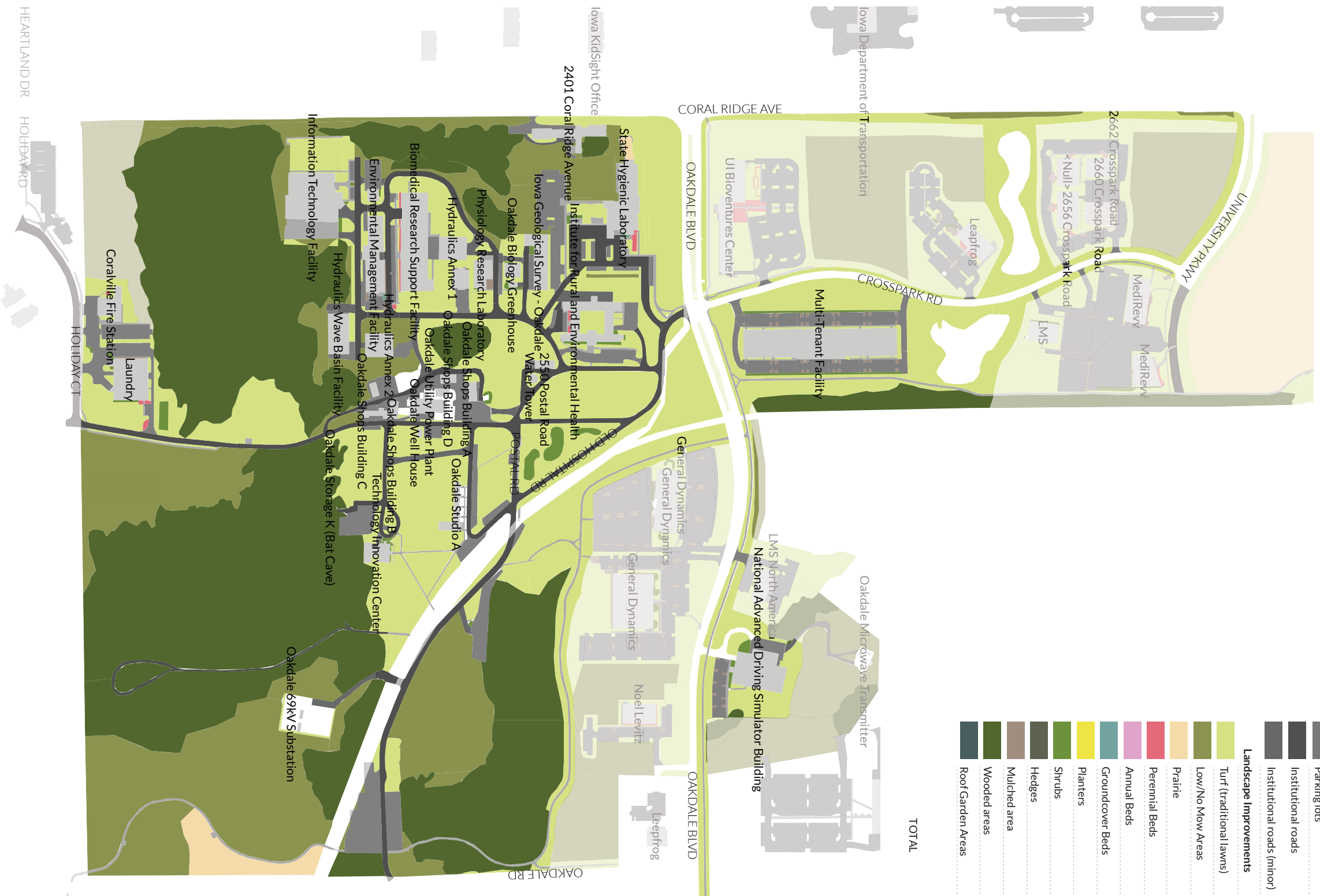

UJHC Support Services Building  
RIDGEWAY DR

**LEGEND & MAINTENANCE PLAN**

Total Sq Ft

UNIVERSITY BUILDINGS	
University Buildings	
BLS Under Construction	
Hardscape Improvements	
Concrete	187,167.46
Colored concrete	
Granite pavers	0
Pavers	0
Parking lots	494,091.50
Institutional roads	
Institutional roads (minor)	456,726.08
Landscape Improvements	
Turf (traditional lawns)	2,339,690.43
Low/No Mow Areas	1,220,429.59
Prairie	278,537.61
Perennial Beds	7,873.01
Annual Beds	0
Groundcover Beds	856.96
Planters	0
Shrubs	48,201.40
Hedges	0
Mulched area	12,331.70
Wooded areas	2,852,824.04
Roof Garden Areas	0
<b>TOTAL</b>	<b>7,898,729.79</b>

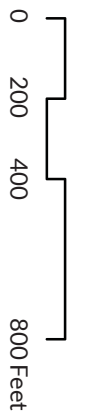

**MAINTENANCE AREA 9**



UNIVERSITY OF IOWA  
LANDSCAPE SERVICES MANAGEMENT PLAN

---

## APPENDIX





## GENERAL PROCEDURE STATEMENT

### WINTER MAINTENANCE – SNOW AND ICE REMOVAL

#### UNIVERSITY OF IOWA FACILITIES MANAGEMENT – BUILDING AND LANDSCAPE SERVICES

The winter maintenance of all building entrances, steps, sidewalks, loading docks, Oakdale parking lots, service drives and institutional roads under the control of the University of Iowa – Facilities Management is the responsibility of Building and Landscape Services. Our goal is to remove snow and ice from traveled surfaces in order to provide safe pedestrian and vehicular traffic. Accumulations of snow and ice will be removed as expeditiously as practical during and after storms within the parameters dictated by weather conditions, available manpower, equipment resources and budget constraints.

During normal working hours (7:00 am to 4:30 pm Monday – Friday), snow and ice treatment will be initiated by the Landscape Services manager and supervisors or their representatives. It is our policy to respond to all snow and ice occurrences.

Outside of normal working hours, including weekends and holidays, SNOW CALLS WILL BE INITIATED BY THE UI DEPARTMENT OF PUBLIC SAFETY AS CONDITIONS REQUIRE. Landscape Services personnel may also be monitoring the weather situation and begin the call – in process.

Regardless of who makes the request for snow / ice removal, Public Safety or Landscape Services, the street snowplow drivers for the main campus and the Oakdale campus are to be contacted first. The plow drivers will call in additional personnel as needed and will initiate the process of calling in the sidewalk and step crews. On the Oakdale campus, where parking lots are under the control of Facilities Management, the main contact person for the Oakdale streets will also call in the parking lot crew.

Call-ins for snow / ice removal can occur any time conditions warrant but if the snow or ice has already fallen, or if the storm is in progress, early morning weekday calls should be started by 2:30 am. Our intention is to have personnel at work and out on their routes by 4:00 am at the latest. We acknowledge that we will have to return to areas later in the day to do a more thorough job, or to clean up snow / ice accumulations that could constitute a safety hazard for evening pedestrian / vehicle traffic.

Weekend call-ins should be initiated so as to have personnel on the job by 7:00 am. **The only exceptions would be on Thanksgiving Day and Christmas Day. Snow and ice on sidewalks and building entrances will be removed the day following the holiday.**

The Landscape Services manager (and / or shop supervisors) will distribute an updated call – in sheet to Public Safety prior to the snow season each year.

Streets and service drives (and parking lots on the Oakdale Campus) will be plowed and treated with a sand / salt mix as needed.

Sidewalks will be plowed and / or broomed and treated with sand / salt or ice-melt mixture.

Building entrances and Steps will be shoveled and treated with a minimal amount of ice melt mixture. Sand is not to be used near building entrances.

Supervisors will provide information and instructions to personnel for areas that require specific practices or procedures that differ from normal service provided. Special requests and emergency service calls will be communicated to employees in the field by use of cell phones.

**UNIVERSITY OF IOWA  
FACILITIES MANAGEMENT – LANDSCAPE  
SERVICES**

**INTEGRATED PEST MANAGEMENT STATEMENT**

Pest control will involve utilizing Integrated Pest Management (IPM) principles to control insect, disease, and weed pests. Pesticides will only be used when a determination has been made that all other options to control the target pest have been ineffective or cannot be used. A definition of IPM is as follows:

“Integrated Pest management is both a concept and a philosophy. It is a broad, multi-disciplinary, systematic approach to controlling pests. All types of control methods (biological, cultural, regulatory, physical, and chemical) are utilized. Use of IPM strategies should result in effective and economical suppression of pests with a minimum effect on non-target organisms and the environment. IPM is based on understanding the plants to be protected and the pests to be controlled.”  
The IPM Program will follow six basic principles:

1. Identify the pest to be managed – not all pests need to be controlled.
2. Define the management area – pest management will vary with campus area and pests.
3. Establish monitoring techniques – a wide variety of methods, from trapping to degree-days, may be employed.
4. Establish thresholds of tolerance – typically damage thresholds will predominate. However, economic and esthetic thresholds may be considered.
5. Develop a prediction model for each target pest.
6. Develop a pest management plans and schedule for each target pest.

Label directions, safety guidelines, and proper record keeping will be followed during pesticide application.

**TREE MANAGEMENT**

Landscape Services is responsible for the management of approximately 6,500 trees at the main campus and 1,500 trees at the Oakdale campus. Criteria to manage the UI urban forest are as follows:

**INSTALLATION**

- The selection of tree species and planting sites for campus tree installation by LS staff will be done collaboratively among the Associate Director of Landscape Services, LS Manager / Landscape Architect, LS Grounds Supervisor, and LS Arborist.
- Service Level A areas that will have trees installed will be scheduled first.
- Service Level B areas that will have trees installed will be schedule second.
- Service Level C areas that will have trees installed will be scheduled third.

**PRUNING, MONITORING, AND REMOVAL  
CONSIDERATIONS**

- Pruning practices shall follow the American National Standards Institute (ANSI) A300 standards. General pruning of Oaks and elms shall be done between the months of November through March to minimize the spread of Oak Wilt and Dutch Elm diseases.
- Service Level A areas shall be inspected monthly for tree pruning needs, monitoring for insect and disease problems, and removal considerations.
- Service Level A tree pruning shall be given to hazard trees. Pruning priorities for clearance, removal of dead wood, structural, and esthetic reasons will follow. Clearance over sidewalks shall be 8 feet, and clearance over streets shall be 14 feet for medium to mature-sized trees per ANSI A300 standards. Scheduling will be done by the LS Arborist and Grounds Supervisor.
- Service level A monitoring for insects and diseases shall be done monthly an based on the tree species that could be affected and the season of the year. Treatment decisions will be determined by the severity of the potential tree damage both physically and esthetically.

- Service Level A tree removal considerations shall be determined based on discussions among the LS Arborist, Grounds Supervisor, Landscape Services Manager / Landscape Architect, and Associate Director of Landscape Services. If a decision is made to remove a tree from a Service Level A area, the appropriate communication will be made to the various stakeholders before the tree is scheduled for removal.
- Service level B tree pruning Service shall be given to hazard trees first; followed by clearance, dead wood, structural, and esthetic considerations. The same clearance standards stated for Level A shall be followed for Level B.
- Service Level C tree pruning shall be given to hazard trees first. Pruning for clearance, removal of dead wood, structural, and esthetic reasons will be done after Level A and Level B areas are done, pending a reason that would put a Level C tree pruning need to supersede pruning from Level A or B areas. The same clearance standards stated for Levels A and B shall be followed for Level C.
- Standards for other tree maintenance practices including watering, staking, mulching, and maintaining valuable trees follow.

#### **WATERING**

- Watering of newly-installed trees shall occur as needed for two years after planting. This applies to Levels A, B, and C.

#### **STAKING**

- Staking is generally not recommended. If staking is required to stabilize a newly-installed tree, three posts shall be placed uniformly around the tree with the connecting wire attached to a strap that won't harm the cambium. The stakes shall remain for one year or until the tree is stable enough to remain upright on its own.

#### **MULCHING**

- All trees growing in the maintained portion of campus shall have a mulch ring with a minimum radius of three feet. The purposes are to protect the tree trunks from mower and

weed-eater damage as well as protecting the tree roots by retaining moisture and lowering soil temperatures. The outer edge of the mulch ring shall have a three to four inch edge dug to keep the mulch from encroaching into the turf and to have a level interface with the turf. A small ring around the base of the tree shall be kept free from mulch to minimize disease pathogens. The mulch depth shall not exceed four inches.

- Service Level A areas with trees not currently having a mulch ring will be scheduled first. Mulched tree rings in Service level A areas shall be refreshed annually.
- Service Level B areas with trees not currently having a mulch ring will be scheduled after Service level A areas are completed. Mulched tree rings in Level B will be refreshed every other year.
- Service Level C areas with trees not currently having a mulch ring will be scheduled after Service levels A and B areas.

#### **MAINTAINING VALUABLE TREES**

- Several campus trees are considered to be valuable based on species, size, location, and condition. An appraised worth based on International Society of Arboriculture – Guide for Plant Appraisal, 9th Edition, criteria of \$10,000 or higher shall define a tree as valuable. These trees are to receive extra consideration for preservation that may require extra resources. Pesticide treatments, lightning protection, air spading, cabling and bracing, and propagation of state champion and other special trees on campus are some of these preservation considerations.

#### **PROTECTION AND PRESERVATION PRACTICES**

- Protection and preservation of existing trees and landscaping will be primary consideration as stated in the UI Design Reference Manual – General Design Standards section. Those trees identified during the design phase will be protected with appropriate fencing. A radius of 1.5 feet per each caliper inch of tree will protect against construction, utility, and trenching activity. Designated lay down areas for construction vehicles, equipment, and supplies will also be identified during the design phase.

## PROHIBITED PRACTICES

- Prohibited tree practices at the University of Iowa include topping and flush cut pruning. Also, pruning of Oaks and Elms during the months of April through October is prohibited, unless deemed necessary due to unusual circumstances. The purpose is to minimize the chances of Oak Wilt and Dutch Elm disease transmissions. During installation, the expectation is that the wire basket and burlap protecting the rootball will be removed from Balled & Burlapped trees.

## TREE INVENTORY

- The University of Iowa Tree Inventory can be accessed by the public at:  
<http://maps.facilities.uiowa.edu/trees/>

## TREE PIT CONFIGURATION

- Tree pits should be as large as possible to allow for ample growing space for tree roots and crown. Optimal tree pit size would be 5 feet by 10 feet by 3 feet deep with a soil volume of 150 cubic feet. Continuous tree pits are encouraged whenever possible and may be given more flexible spacing requirements. Tree pits shall be continuous whenever group plantings are involved.
- Group plantings are encouraged due to the benefits of trees in close proximity. These benefits include increased shading, less evapotranspiration, less soil compaction, greater shared soil volume, and less reflective heat absorbed by a single tree. A grouped planting can be achieved in several types of sites: (1) a green street, such as a median or traffic triangle, with the opportunity for a large planting bed; (2) a continuous tree pit, where two or more trees are planted in a single trench in the sidewalk (at least 30 feet long); or (3) a raised planting bed as within a plaza or alongside a pedestrian passageway.
- Species selection is very important in group plantings. Tolerant species are strongly recommended and monoculture plantings are discouraged. Low maintenance cost and low replacement costs are two advantages of planting tolerant species in grouped configurations.

## LS TURF PROGRAM

### DRY APPLICATION

- April 3-7
- Aerify
- Gypsum 2 lbs. per 100

### ROUND 1

- April 17-21
- Holganix 14 oz. per 1000
- Foliar 18-3-6 6 oz. per 1000
- Dimension 1 qt/A
- Defendor .25 qt/A

### ROUND 2

- June 5-9
- Holganix 7 oz. per 1000

### ROUND 3

- July 17-21
- Holganix 7 oz. per 1000
- 4-0-1 w/Promote 6 oz. per 1000
- Imidachlopid 6 oz. per 1000

### ROUND 4

- August 28-September 1
- Holganix 7 oz. per 1000

### DRY APPLICATION

- September 18th
- Aerify
- 46-0-0 1 lb. per 1000

### ROUND 5

- October 23-27
- Holganix 7 oz. per 1000
- Dimension 1 qt/A
- Defendor .25 qt/A

### DRY APPLICATION

- October 30-November 3
- Gypsum 2 lbs. per 1000

## IRRIGATION MAINTENANCE SCHEDULE

### GENERAL

- System Pressure Monthly
- Pump Stations Weekly
- Filters – Mainline Monthly
- Filters – Supply Line (Auto. Hyd. Sys) Weekly
- Electrical Source Output (Auto Sys) Monthly

### PUMP STATIONS

- Pump Operation Bi-Weekly
- Pressure Output Weekly
- Screening Devices Monthly
- Sump Area Monthly
- Motor – Supply Voltage, Amperage Annually
- Motor Upper & Lower Bearings
- Grease Lube 1000 Hours
- Oil Lube (Change Oil) or 3 Months
- Pump Packing Box – Adjust & Grease Monthly
- Control Valve
- Strainers 2 Months
- Pilot Valves Annually
- Diaphragm & Seats (Dirty H2O) Annually
- Bowls, Shafts, Impellers Inspection Low Output Pressure

### CONTROLLER (AUTOMATIC SYSTEMS)

- Operation – Progression; Sta to Sta Weekly
- Proper Activation of Valves Monthly
- Proper Timing of Stations Bi-Annually
- Proper Time & Day Readings Weekly
- Heat Strips, Bulbs, Resistors (Cold Weather) Weekly
- Fuses Weekly
- Moisture Collection (Operation Moist Sensing Devices) Monthly
- Exterior Appearance Bi-Annually

### VALVE OPERATION

- Open, Close Completely (Weeping) Weekly

### SPRINKLER OPERATION

- Rotaries - Clogged Nozzles Bi-Monthly
- Plant Obstruction Pattern, Arc Coverage,
- Radius Adjustment, Pop-Up Action,

- Riser Seal Leaks Bi-Monthly
- Set to Grade, Coverage-Pressure,
- Rotational Speed, Clogged Screens,
- Head Damage, Swing Joint Damage,
- Impacts – items listed under Rotaries,
- Spring Tension, Bent or Maladjusted arm,
- Spoon Breaker, Proper Reversing (p/C) Bi-Monthly

### QUICK COUPLER VALVES

- Broken or Missing Hinged Covers,
- Leaking or Weeping Valves Monthly

### PIPING

- Leaks – Broken or Cracked Pipe, Bad
- Solvent Welds, Bad Threaded
- Connections, Clogged Pipes As Needed

### WINTERIZATION

- Manual – Drain Down, Valves
- And Controls Open, Pressurized
- At System Rating Same Conditions As Needed

**NOTES:** During initial charging or recharging of system, be sure to SLOWLY open main valve allowing sufficient time to bleed off all entrapped air before completely opening main valve. Also open any high points of systems (heads and valves) and dead ends of piping to be sure all air is evacuated from system. This is a suggested guideline – for your system’s maintenance schedule, local conditions must be considered, such as water quality, climatic changes, down seasons, system use, etc.

## UNIVERSITY OF IOWA SCHEDULE FOR POND MANAGEMENT

### APRIL

- Aerator: Install new air filters and start up the compressor for the year if turned off for the winter. Record the operating pressure of the compressor.
- Begin making applications of Nature's Blend every two weeks when the water temperatures reach 50-60°F.
- Make the initial pond dye application.

### MAY

- Check for submerged aquatic plant growth and consider a spot application of herbicide if growth is excessive.
- Make an additional pond dye application if rains have diluted the concentration.
- Continue making Nature's Blend applications in a scheduled manner.

### JUNE

- Make an application of MD Pellets to digest the muck on the bottom of the pond.
- Make an additional pond dye application if rains have diluted the concentration.
- Continue making Nature's Blend applications in a scheduled manner.

### JULY

- Aerator: Check and replace filters as needed.
- Record the operating pressure of the compressor.
- Monitor algae and duckweed levels and make spot herbicide applications if needed. If an algaecide is used, wait 1-2 days until making another Nature's Blend application.
- Consider making another application of MD Pellets to further digest organic muck on the bottom of the pond.
- Continue making Nature's Blend applications in a scheduled manner.

### AUGUST

- Check for late season submerged aquatic plant growth and consider a spot application of herbicide if growth is excessive.
- If surface scum from seasonal plant breakdown is unattractive consider making a spot application of Elemental Basic to break up the scum.
- Continue to monitor and spot treat algae and duckweed. If an algaecide is used, wait 1-2 days until making another Nature's Blend application.
- Consider making another application of MD Pellets to further digest organic muck on the bottom of the pond.
- Continue making Nature's Blend applications in a scheduled manner.

### SEPTEMBER – OCTOBER

- Aerator: Check and replace filters as needed.
- Record the operating pressure of the compressor.
- Continue making Nature's Blend applications in a scheduled manner until water temperatures fall below 50-60°F.

### NOVEMBER – DECEMBER

- Aerator: When temperatures cool, consider shutting down the aerator for the winter to conserve energy and minimize wear on the compressor.



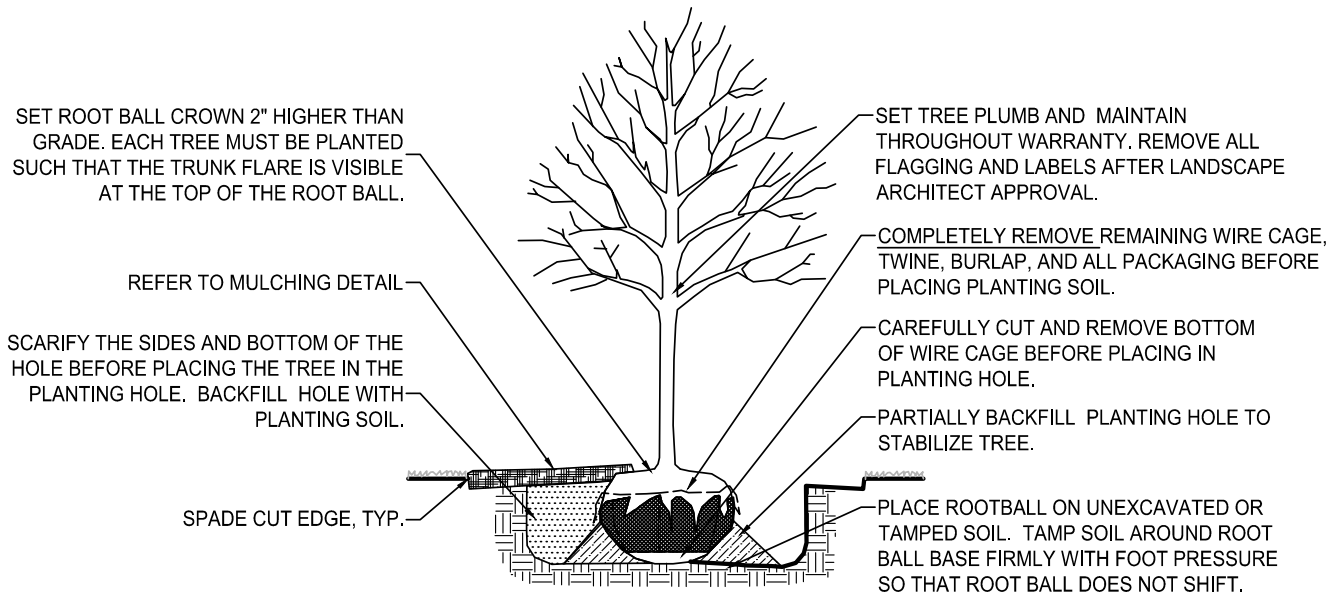

## TREE PLANTING

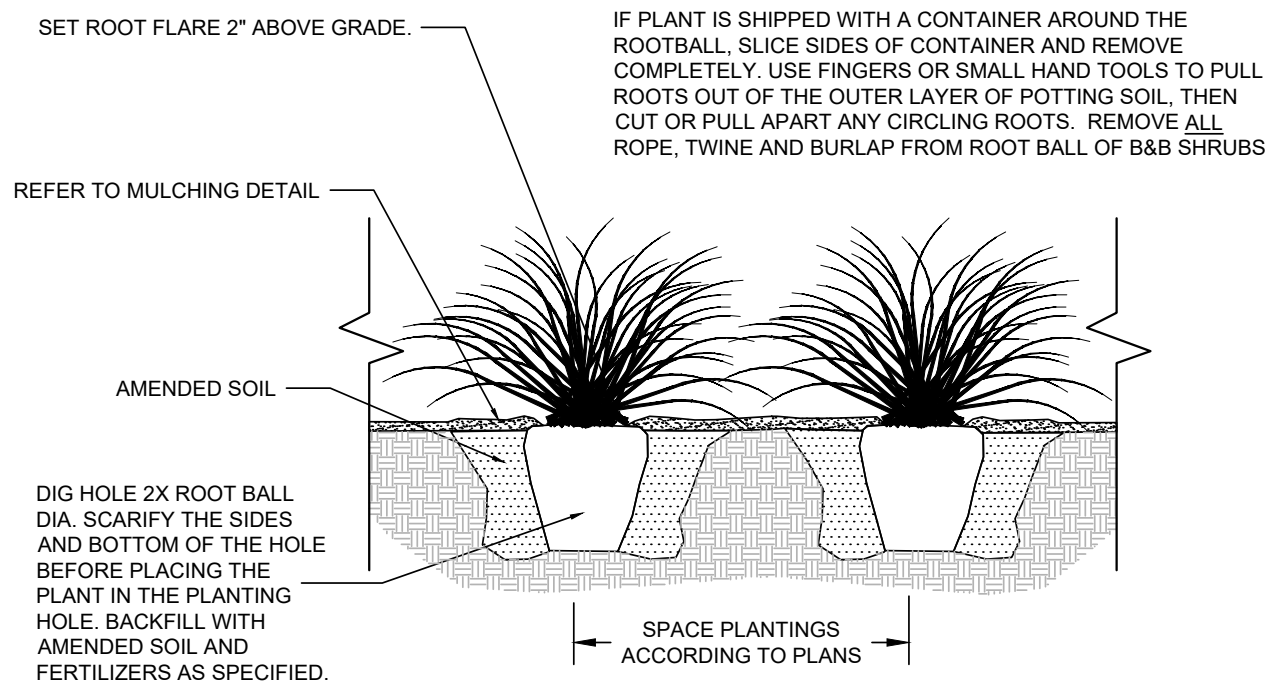

## SHRUB / PERENNIAL PLANTING

PROVIDE 1" DEPTH OF MULCH COVERAGE NEAR TRUNK FLARE. DO NOT PLACE IN CONTACT WITH TRUNK. PROVIDE A MIN. 6" DIA. MULCH FREE RING AROUND TRUNK.

PROVIDE PRE-EMERGENT APPLICATION (BROADSTAR) IN APRIL, JULY, AND SEPTEMBER.

TREES SHALL HAVE MULCH CIRCLES WITH A 3' MIN. RADIUS.

TAPER DOUBLE SHREDDED HARDWOOD MULCH RING FROM 1" - 4" DEPTH. TAPER TOP OF MULCH TO TURF LINE.

TURF

4" DEPTH SPADE-CUT EDGE, TYP.

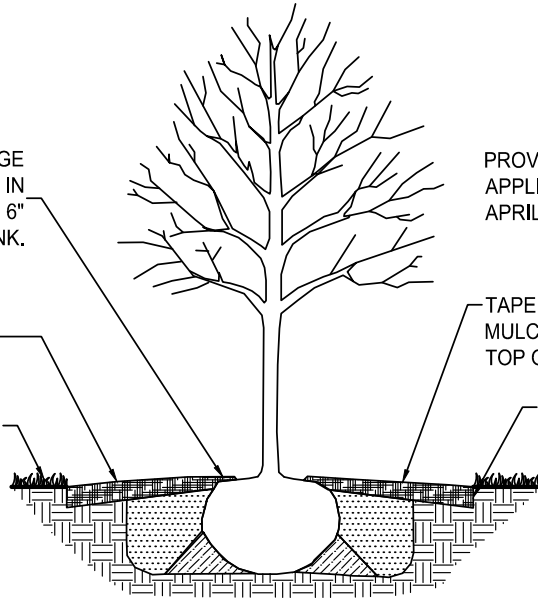

## TREE MULCHING

PROVIDE 1" DEPTH OF MULCH COVERAGE NEAR ROOT FLARE. DO NOT PLACE IN CONTACT WITH CROWN. PROVIDE A MIN. 3" DIA. MULCH FREE RING AROUND CROWN.

PROVIDE PRE-EMERGENT APPLICATION (BROADSTAR) IN APRIL, JULY, AND SEPTEMBER.

TAPER MULCH TO 4" DEPTH AT PAVEMENT EDGE. TOP OF MULCH SHALL BE FLUSH WITH THE TOP OF PAVEMENT.

HARDWOOD MULCH

4" DEPTH SPADE-CUT EDGE

TURF

SIDEWALK

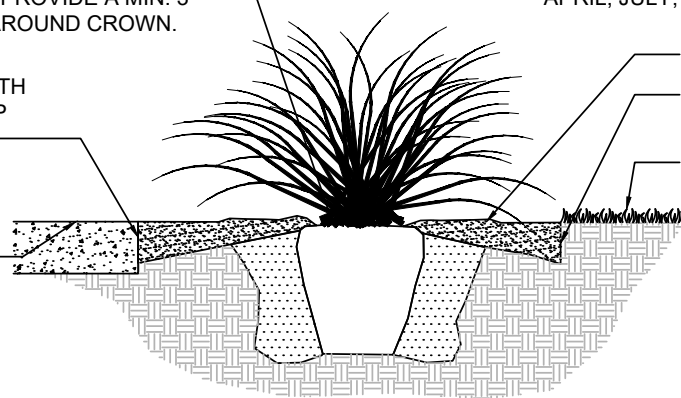

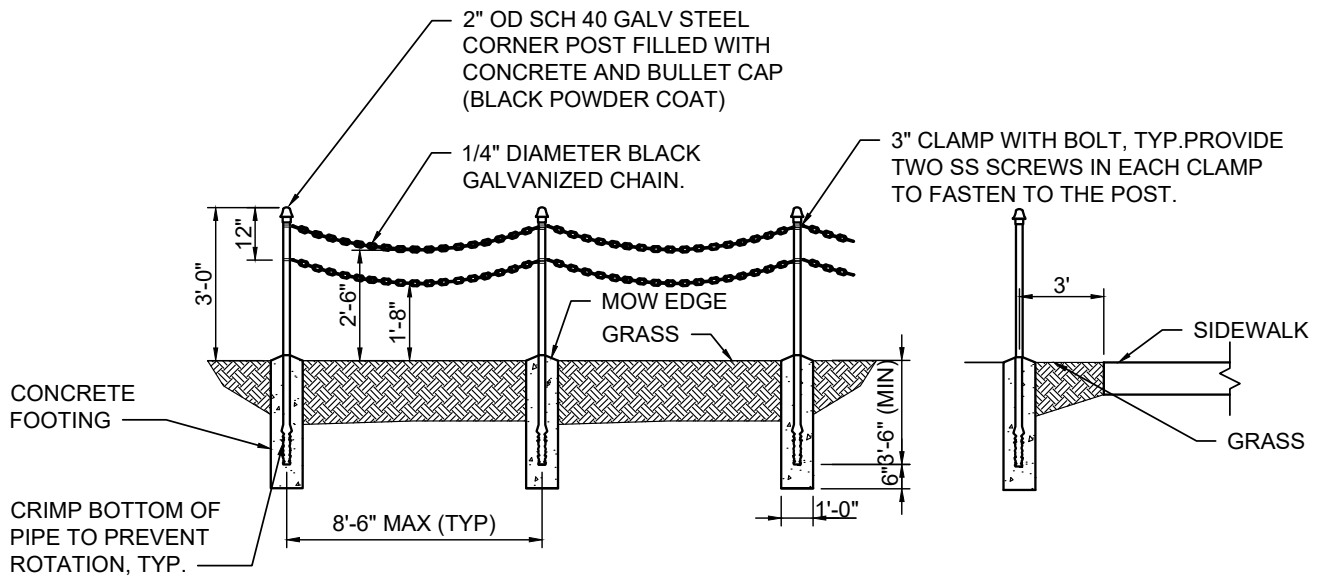

## POST & DOUBLE CHAIN INSTALLATION

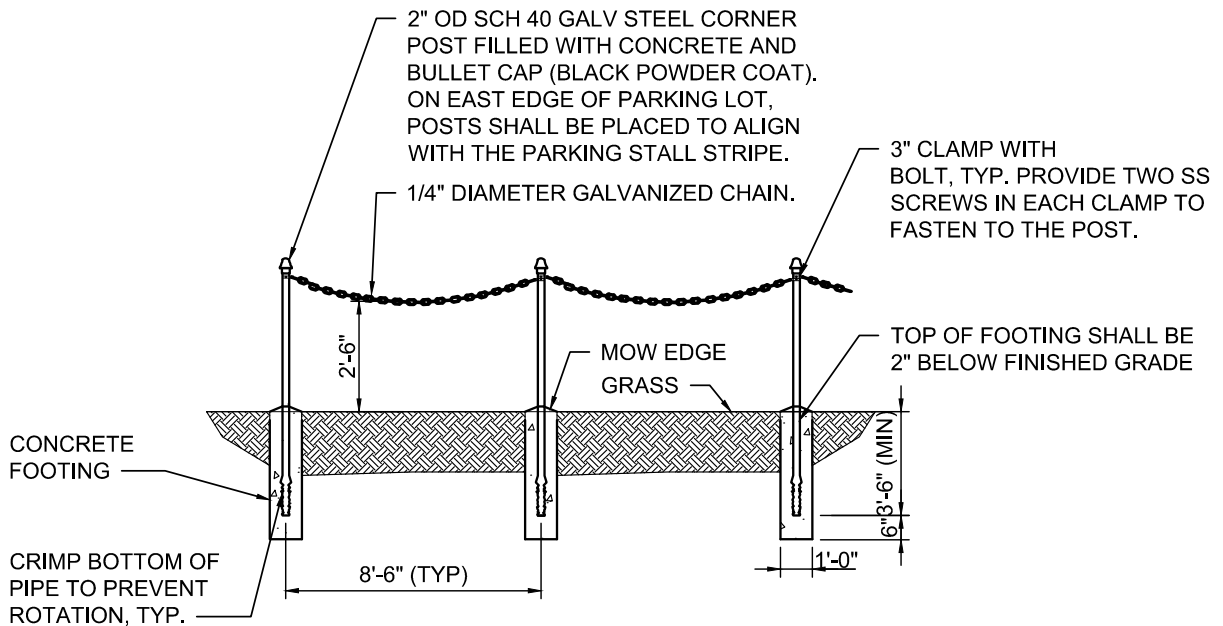

## POST & SINGLE CHAIN INSTALLATION

# Basic Wall Installation

## Getting Started

### Step 1 - Base Course Preparation

Beginning at a point of the wall's lowest elevation, excavate a trench down the length of the wall that will accommodate at least 6" of base material and 6" of block embedment. As a rule of thumb, for every 8" to 10" of wall height, 1" of block should be buried with at least a minimum of 6" base course embedment. Step the trench up or down with respect to adjacent grade.

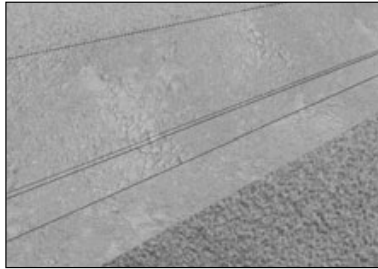

The width of the trench for a Classic®, or Classic Colonial™ wall should be a minimum of 24", while the trench width for a Legend® wall should be a minimum of 34". Based on the type of application and what is retained, the depth of the leveling pad may vary. If necessary, consult with an engineer.

After excavating the native soil and prior to adding base material, remove loose material from the trench and compact.

### Step 2 - Leveling Pad Installation

Place and compact a minimum of 6" base material to 95% Standard Proctor. Verify that the base is level with a transit or hand level. Be aware that the base material (commonly referred to as road base or base aggregate) will vary from region to region.

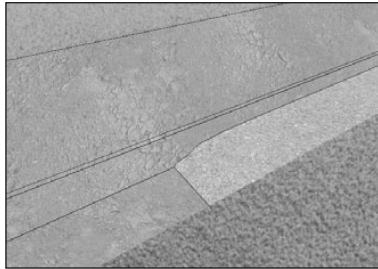

### Step 3 - Base Course Installation

The base course will consist of base block. Use a string line behind the tail of the block for alignment on straight wall applications. All blocks should rest firmly on the pad and be centered to allow 6" of base material in front and 6" behind the Base Block. Level each block, side-to-side, front-to-back and across

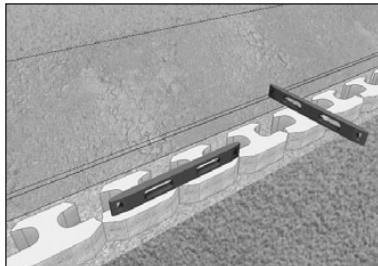

three full blocks with a hand level. A rubber mallet may be used to level and align the blocks.

### Step 4 - Core and Drainage Fill

Place 3/4" to 1" clean aggregate (crushed rock) within the cores and a minimum of 12" behind the blocks. This creates a drainage zone and Stone Columns that helps to unify and maximize the performance of the wall.

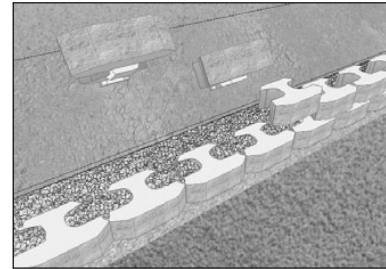

### Step 5 - Successive Course Installation

Prior to adding successive courses, the top of each block needs to be clean and free of foreign material. Center the block and pull it forward until the Anchor Bar abuts the two blocks below it. Place core and drainage fill as in Step 4. Place the backfill material behind the drainage rock in maximum of 8" lifts and compact to 95% Standard Proctor. Repeat this process for each successive course.

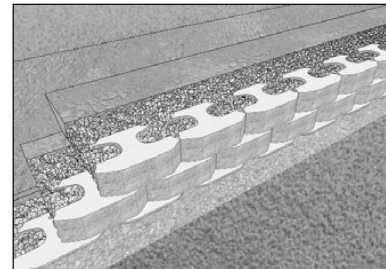

Large compaction and construction equipment should be kept a minimum of 3' from the back of the wall. This 3' area should be compacted with a vibrating plate compactor.

*"Stone Columns" are an integral part of a Rockwood Retaining wall; adding support and stability to the wall.*

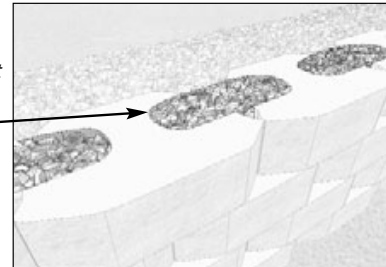

Know what's below.  
Call before you dig.

### Step 6 - Capping a Wall

The Universal Cap has both a finished surface and palletized surface. The finished surface should be exposed on the top course to complete the wall application.

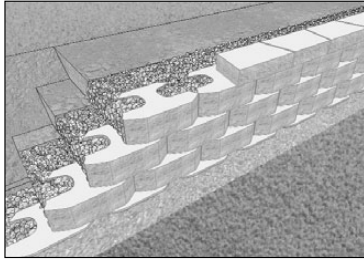

The adhesive used for securing cap units should have a high rubber content. Check with your supplier to determine which concrete adhesive is recommended if Super-Stik™ adhesive is not available.

To ensure permanent placement of the upper blocks, adhesive should be used.

### Step 7 - Stepping a Wall

A Half Block or Corner Block may be used to end a course in a Rockwood application.

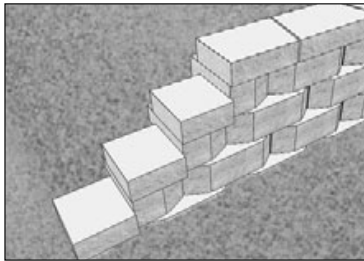

Double stack 4" tall Universal Caps as an end cap to finish courses of 8" tall blocks.

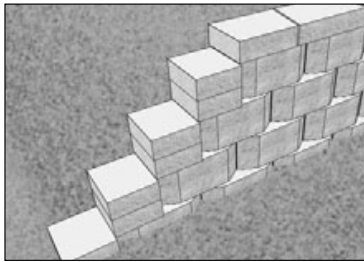

### Special Applications

While the installation steps presented are applicable to most basic wall designs, special consideration needs to be given to those applications in which a slope, surcharge loading, and/or less than ideal soils are present. These types of applications may require geosynthetic reinforcement or other engineering design support. Such applications include, but are not limited to:

- Wall Height
- Tiered Wall
- Driveways and Roads
- Bridges and Culverts
- Fences and Guardrails
- Water Applications
- Drainage
- Structures

Please refer to the geosynthetic reinforcement section for more information in regard to the incorporation of geosynthetic reinforcement in wall design.



# Special Applications

## Convex and Concave Curves

### Step 1 - Base Course Preparation for a Convex or Concave Curve

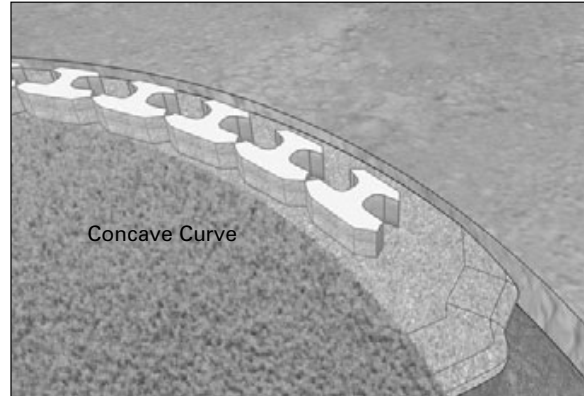
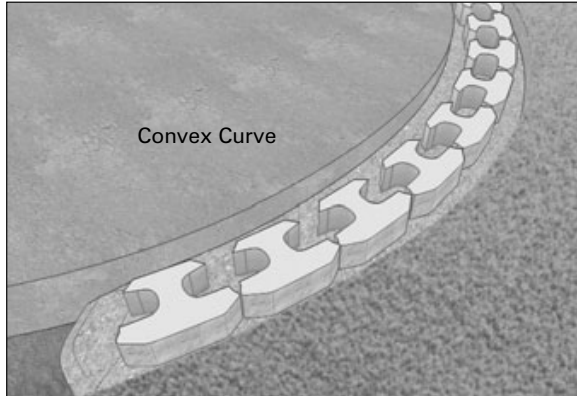

Place the blocks on the leveling pad so there are no gaps between them.

### Step 2 - Successive Course Installation for a Convex or Concave Curve

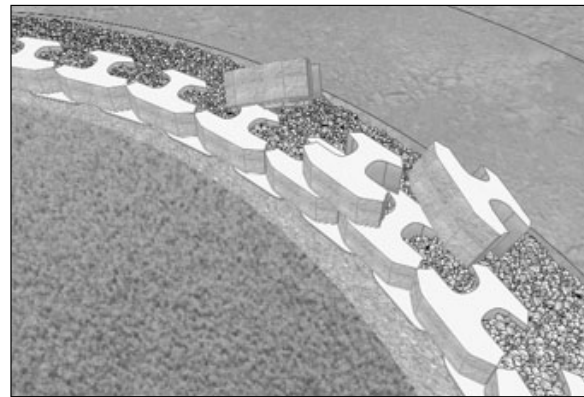

When building multiple courses on a curve, begin installation by placing a block in the middle of the curve and centering it on two blocks directly below it. Build the wall from the center block outward.

### Step 3 - Cutting Universal Caps for Curved Walls

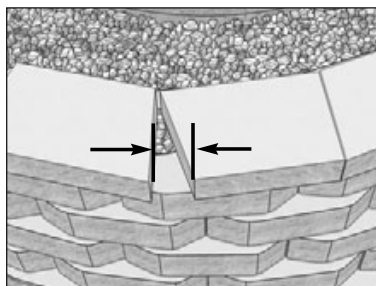

Place the Universal Caps and measure the distance of the gap between the caps.

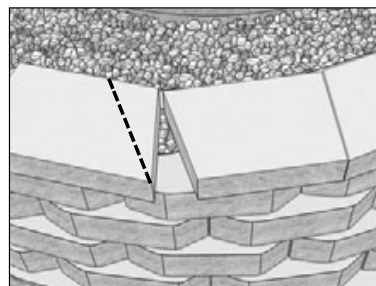

Using this measurement, cut the cap so that it is parallel with the adjacent cap unit.

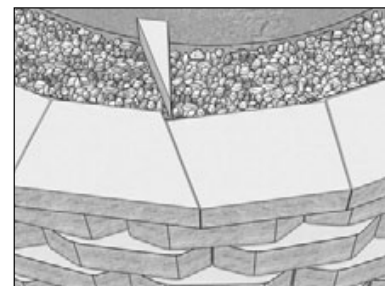

Slide the cap in place so that it is flush with the adjacent cap unit. Adhere caps with Super-Stik™.

## Outside 90° Corner

### **Step 1 - Base Course Preparation with Corner Block**

Begin an outside corner from the corner of the wall and install the blocks from the corner out when possible.

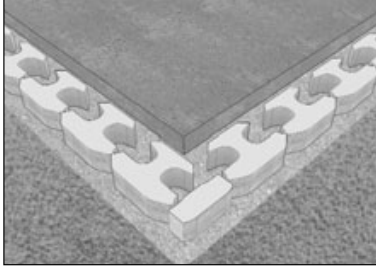

### **Step 2 - Successive Course Installation**

Stagger the Corner Block as each successive course is installed so it is on the opposite side of the wall corner. Length adjustments to the Corner Block may be necessary to maintain a running bond.

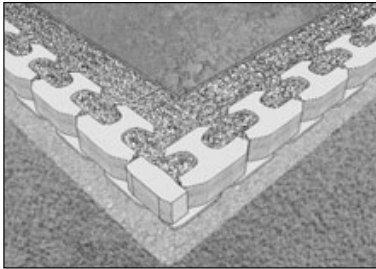

### **Step 3 - Finishing a Outside 90° Corner**

Using a hammer and chisel, score and split a Universal Cap four inches from one side. Position it on the corner with one or two inches of overhang.

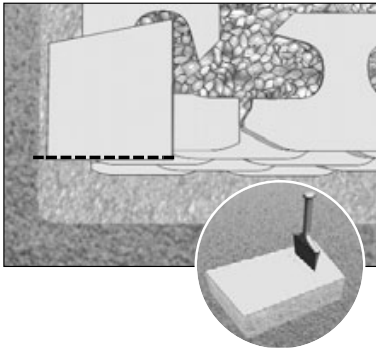

Cut another Universal Cap to be placed on the adjacent corner wall so that it is flush with the other cap unit. Adhere Universal Caps with Super-Stik™.

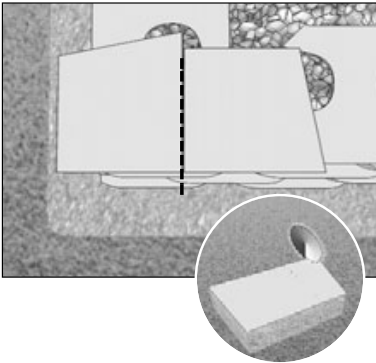

## Inside 90° Corner

### **Step 1 - Base Course Preparation**

Begin an inside corner from the corner of the wall and install the blocks from the corner out when possible. Only half of a whole block installed on the corner will be exposed. This is true of each successive block that is staggered in the corner.

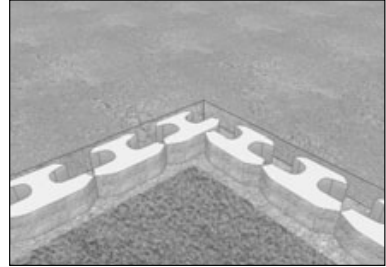

### **Step 2 - Successive Course Installation**

Gaps will develop in successive courses, which will require a "wedge" block to fill the gap. Measure the gap and cut a block to fill the gap. Adhere cut block with Super-Stik™. Depending on the height of the wall, the "wedge" block will eventually become the same size as a whole block, then the process repeats itself.

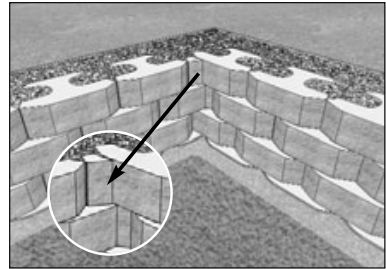

### **Step 3 - Finishing an 90° Inside Corner**

Using a hammer and chisel or a masonry saw, cut a Universal Cap so it is perpendicular to the wall face.

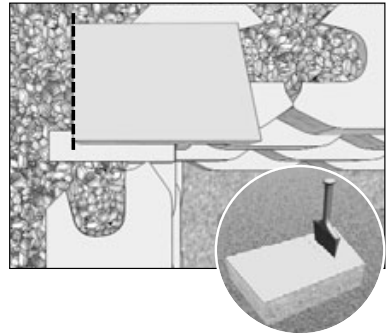

Cut the next Universal Cap to be flush with the corner cap. Adhere Universal Caps with Super-Stik™.

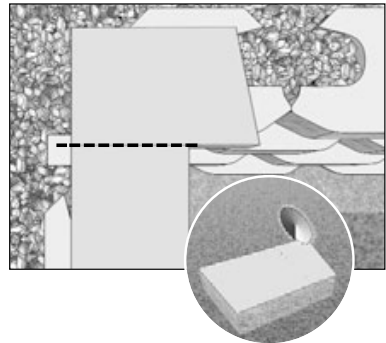

# Special Applications

## Basic Stair with Universal Cap

The installation described below using Rockwood's Classic® 6 and Universal Caps is for a basic stair step application. It is recommended the riser width be considered in 18" increments for this particular application. This will ensure full blocks fit the width of the stair steps without having to cut them, since each block is 18" in width. Beveled blocks may be used for this application, but straight face blocks offer a more uniform and straight finish.

### Step 1 - Dimensions of the Steps

The step rise is 6". The step depth is 10". To determine the number of risers needed, divide the height of the stair by the riser height. To determine the length of the side stair walls, multiply the depth by the number of risers.

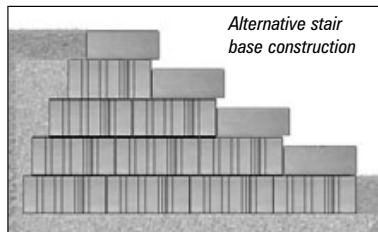
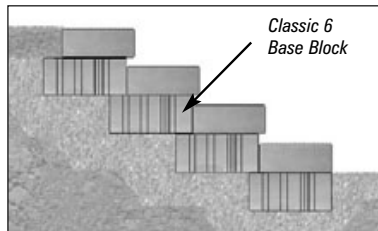

### Step 2 - Excavating the Trench for the Base

Follow the standard procedures for base course installation and place the blocks on the leveling pad so there are no gaps between them.

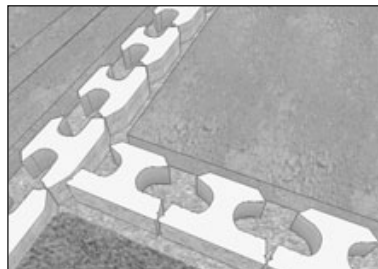

### Step 3 - Setting Successive Risers

Excavate for a minimum of 6" of base material under all risers. Proper compaction to 95% Standard Proctor is crucial in a stair step application. Each successive riser should overlap the previous riser by 2". Fill the cores and backfill behind the wall with the base material to 95% Standard Proctor. Repeat this process for each successive riser. The side stair walls must be vertical with no setback.

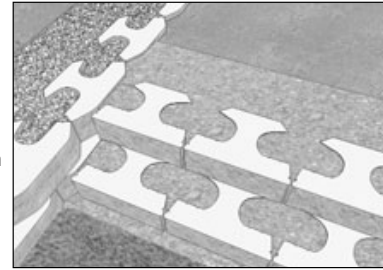

When capping risers, make sure the top of the risers are swept free of any foreign material.

## Basic Stair with Step Tread

The installation described below uses Rockwood's Step Treads and is for a basic stair step application. It is recommended the riser width be considered in 8" increments for this particular application. This will ensure full blocks fit the width of the stair steps without having to cut them, since each block is 8" in width.

### Step 1 - Dimensions of the Steps

The step rise is 6". The step depth may vary from 10" to 13". To determine the number of risers needed, divide the height of the stair by the riser height. To determine the length of the side stair walls, multiply the depth by the number of risers.

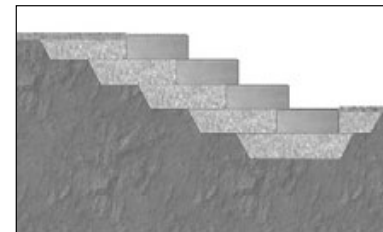

### Step 2 - Excavating a Trench for the Base

Follow the standard procedures for base course installation and place the blocks on the leveling pad so there are no gaps between them.

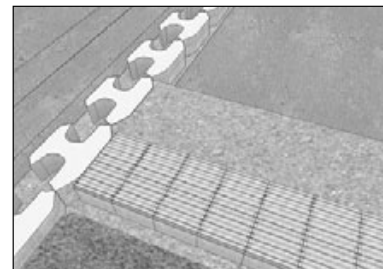

**ROCKWOOD®**  
RETAINING WALLS  
*A better way.™*

Visit us on the web at:  
[www.rockwoodwalls.com](http://www.rockwoodwalls.com)



### Step 3 - Setting Successive Step Treads

Excavate for a minimum of 6" of base material under all Step Treads. Allow for the base material to extend a minimum of 18" behind each successive course of Step Treads.

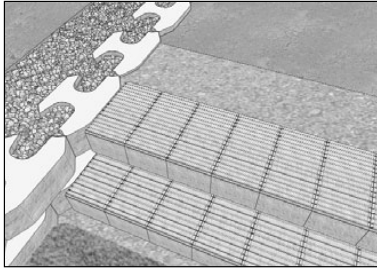

Proper compaction to 95% Standard Proctor is crucial in a stair step application. Each successive Step Tread should overlap the previous riser by 2" to 5". Repeat this process for each successive riser. The side stair walls must be vertical with no setback.

### Branched Wall

Branched walls require a minimum of one course embedment, as if each wall is independent.

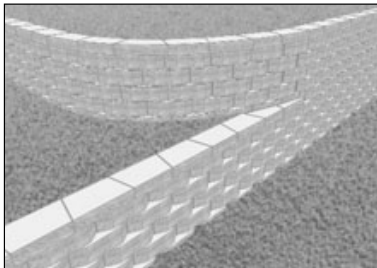

### Tiered Wall

Tiered walls may be installed where it is desirable or aesthetically pleasing to use more than one wall. Upper walls can exert surcharge loads on lower walls. In order to design tiered walls independently, the walls must be set back a distance of at least twice the height of the lower walls. Whenever tiered walls are constructed, a qualified soils engineer should be consulted.

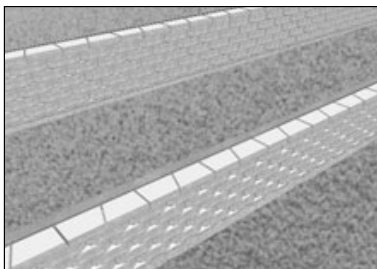

### 20" Pillar

#### Step 1 - Create a (Corner) Pillar Block

Your distributor may carry Corner Blocks. If you need to create corners on the job site, see instructions on page 7 on how to create Corner Blocks.

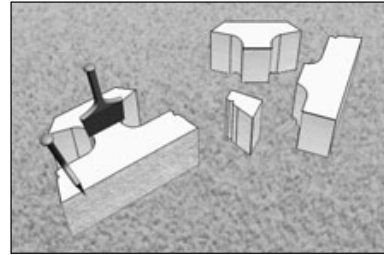

#### Step 2 - Excavating and Site Preparation

Follow the steps for a leveling pad installation, as described in basic wall installation. Lay the first four pillar blocks with the split faces exposed to create the foundation for the 20" Pillar.

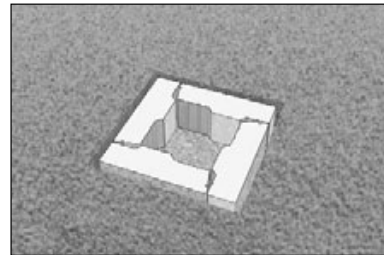

#### Step 3 - Successive Course Installation

Stagger the pillar blocks so a running bond is maintained. Adhere all blocks with Super-Stik™.

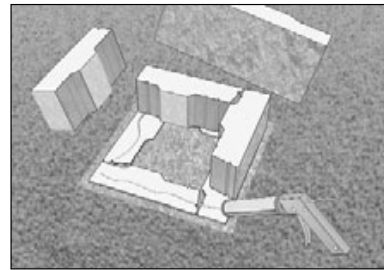

#### Step 4 - Capping a 20" Pillar

A 20" Pillar may be capped with Universal Caps, stone, or other prefabricated products. Adhere caps with Super-Stik™.

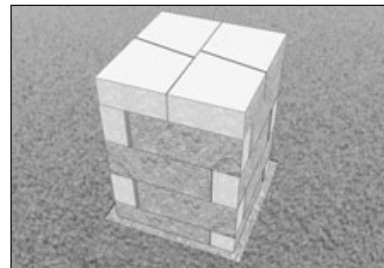

# Special Applications

## Half Block Pillar (Base Block)

### Step 1 - Create a Half Block

Your distributor may carry Half Blocks. If you need to create Half Blocks on the job site, be sure you have Base Block

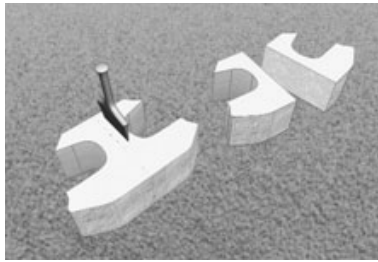

### Step 2 - Excavating and Site preparation

Follow the steps for a leveling pad installation, as described in basic wall installation. Lay the first four Half Blocks with the split faces exposed to create the foundation for the Half Block Pillar.

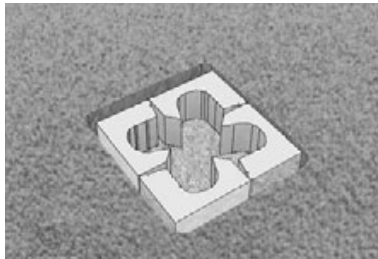

### Step 3 - Successive Course Installation

Stagger the Half Blocks so a running bond is maintained. Adhere all blocks with Super-Stik™.

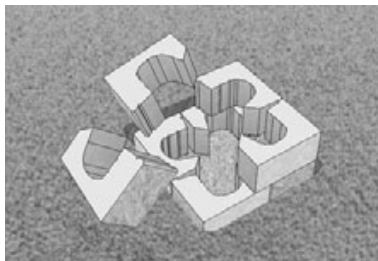

### Step 4 - Capping a Half Block Pillar

A Half Block Pillar may be capped with Universal Caps, stone or other prefabricated products. Adhere caps with Super-Stik™.

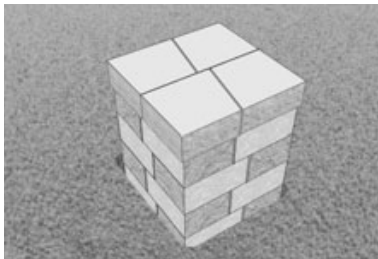

## Fences, Posts and Guardrails

Special consideration must be taken when designing a retaining wall that includes fence or guardrail posts.

Sleeve-It™ is a proven system that uses a traditional cantilever design to engage the overlying soil mass, thereby providing resistance to the fence load. Sleeves should be installed as the wall is constructed. In reinforced walls, geogrid will need to be cut to fit around the Sleeve-It. Consult with an engineer in regard to design and application.

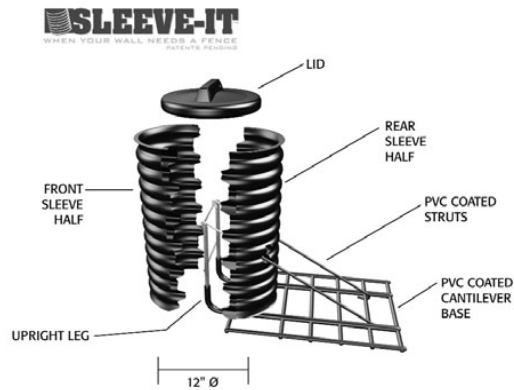

770-888-6688 • [www.fencesleeve.com](http://www.fencesleeve.com)

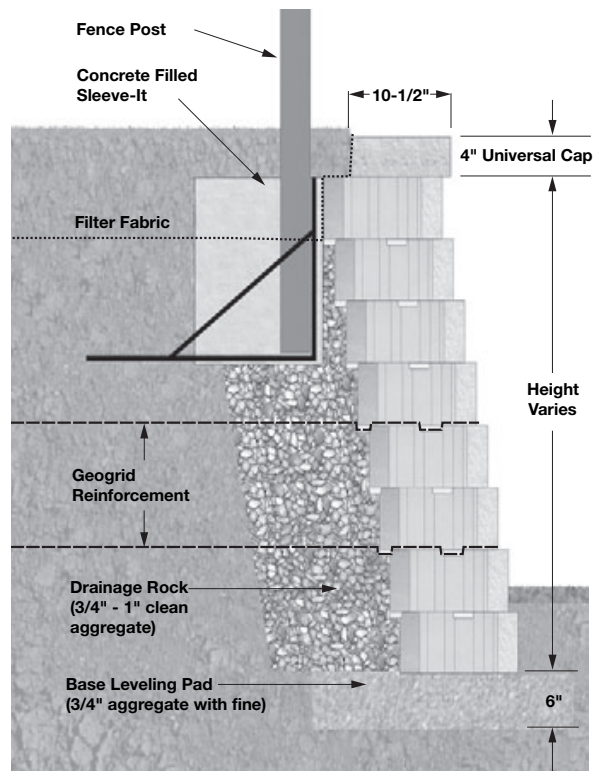

## Vertical Wall

Rockwood's blocks offer the unique ability to modify the facing batter of a wall. This is especially useful in stair step and egress window applications. For 6" tall Blocks, adjust setback by 3/4". For 8" tall Blocks, adjust setback by 1". The setback is determined by how much material is removed.

To adjust the setback, modify the two blocks below the successive course by splitting at the grooves on the top of each block.

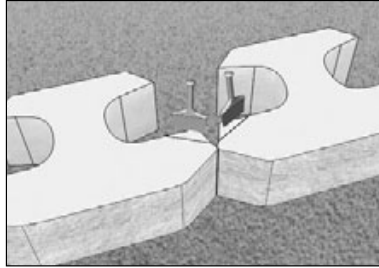

**NEVER ALTER THE ANCHOR BAR!**  
Doing so will adversely affect the performance of the wall.

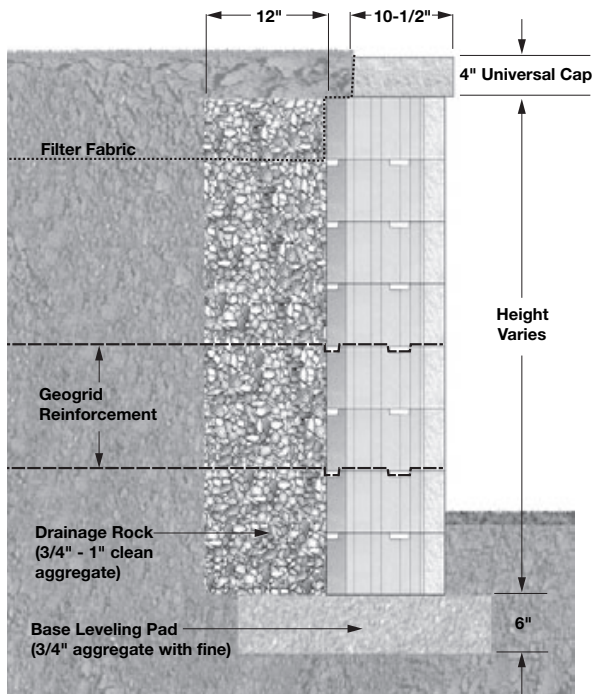
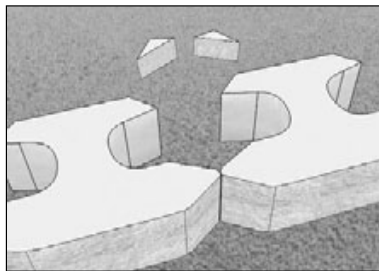

## Water Applications

Retaining walls constructed along or around retention ponds, shorelines, and other bodies of water require special consideration. Design considerations include drainage, foundation strength, erosion or scouring at the base of the wall, freeze thaw, and hydrostatic pressure. It is recommended that a qualified engineer design an application that may be subject to these conditions.

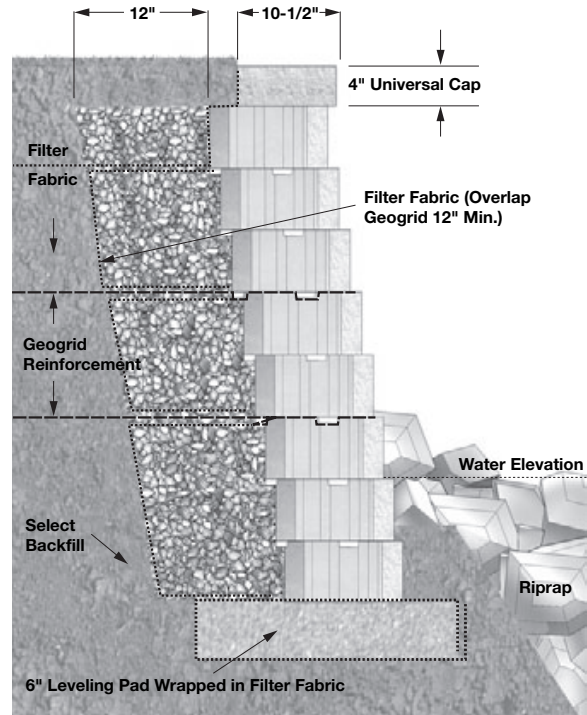

**ROCKWOOD®**  
RETAINING WALLS  
*A better way.™*

Visit us on the web at:  
[www.rockwoodwalls.com](http://www.rockwoodwalls.com)

# Geosynthetic Reinforcement

## Geosynthetic Reinforcement

Geosynthetic reinforcement is an engineered product that is typically comprised of polypropylene, polyester, or other high tensile material. Used in conjunction with segmental retaining wall blocks, it helps stabilize the soil mass behind a wall. Depending on the wall design, the length and the number of grid layers will vary.

Generally, grid strength is in the roll direction. As it is unrolled, it is in the same direction it should be installed. Biaxial grid is another option in which the strength is the same against roll direction as it is in the roll direction.

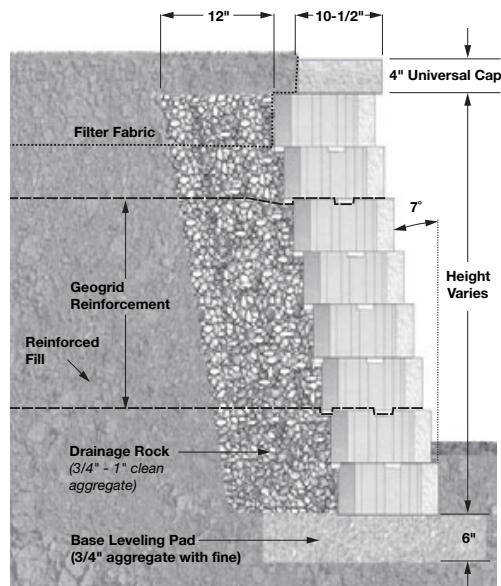

## Basic Grid Reinforcement

### Step 1 - Preparation for Grid

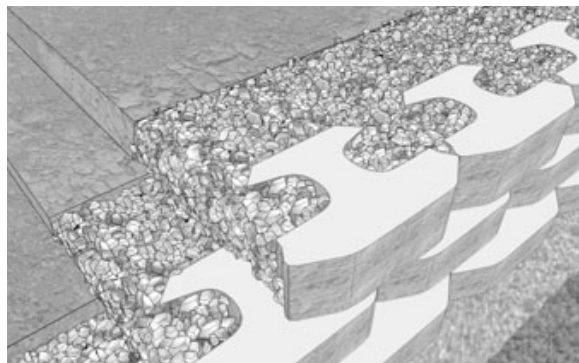

The area behind the wall on the grid layer needs to be level with the top of the block and to 95% of the Standard Proctor (ASTM D698).

### Step 2 - Grid Placement

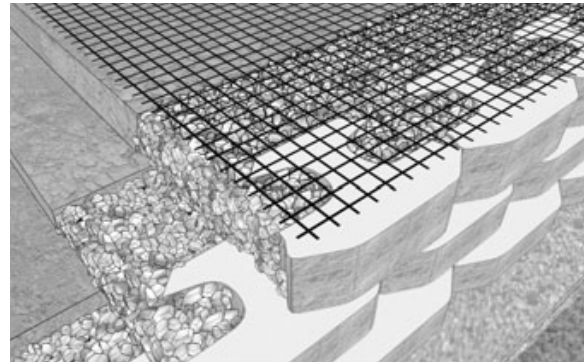

Place the grid as close to the face of the wall without exposing it after successive placement of blocks. Ensure the grid is placed with the strength direction perpendicular to the wall. Check grid manufacturer specifications for proper grid placement instructions.

### Step 3 - Preparation for Backfill

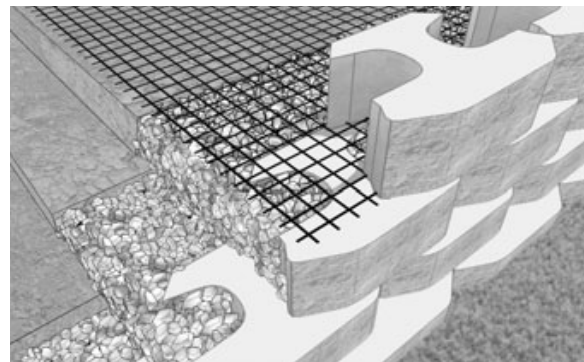

Place the next course of block. Pull the grid back and stake it so it is taut and free of wrinkles.

### Step 4 - Backfill and Compact

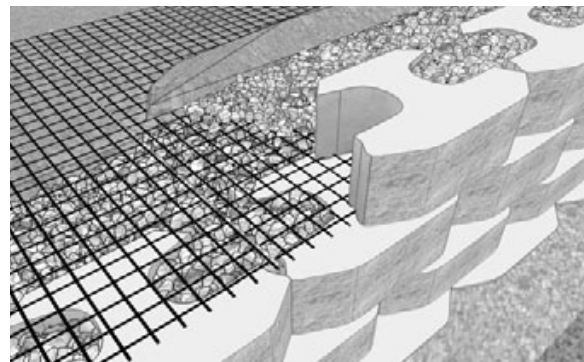

Place 3/4" to 1" clean aggregate (crushed rock) within the cores and a minimum of 12" behind the blocks. Place and compact backfill on the grid in lifts no greater than 8". When possible, it is recommended the backfill is deposited directly behind the wall and pushed to the end of the grid to ensure it remains taut and wrinkle-free.

## Geosynthetic Reinforcement - Convex Curve

### Step 1 - Grid Placement

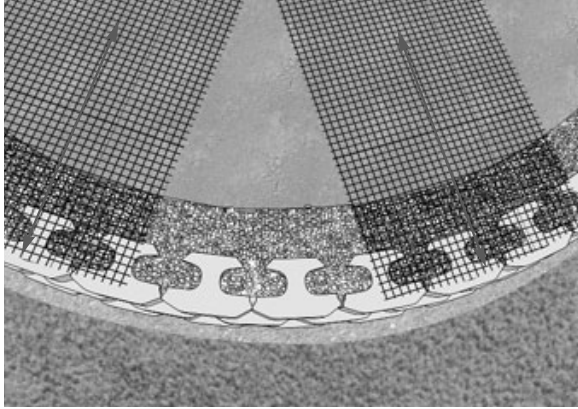

Place grid following the contour of the curve.

### Step 2 - Successive Grid Layers

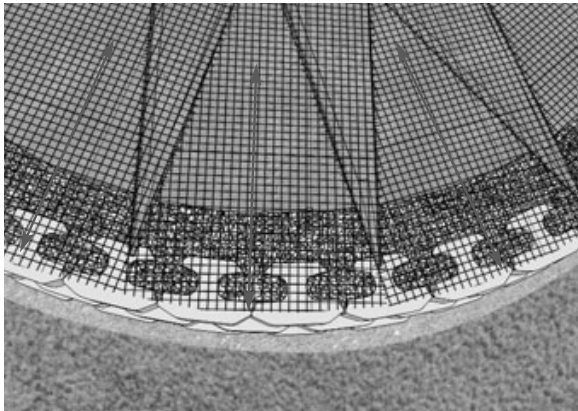

Overlapping layers of grid on a convex curve require a minimum of 3" of fill between them for proper anchorage. Repeat these steps for successive specified grid layers.

## Geosynthetic Reinforcement - Concave Curve

### Step 1 - Grid Placement

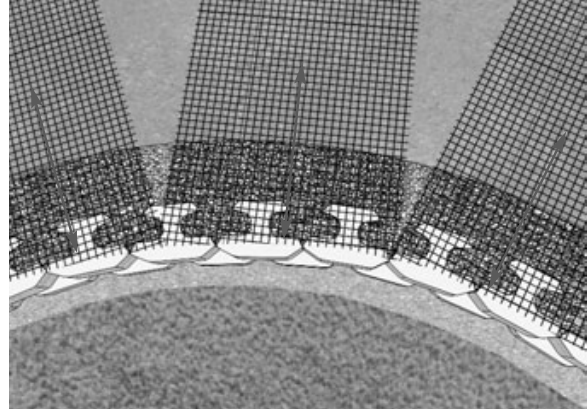

Making sure the strength direction of the grid is perpendicular to the wall face, align the cut grid sections so they follow the contour of the concave curve. Grid layers should not overlap. An engineer will specify grid lengths.

### Step 2 - Successive Grid Layers

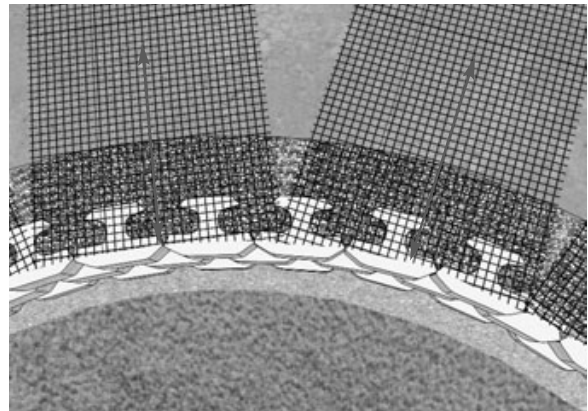

After the next course of block is placed, lay the grid to cover the area of unreinforced soil below. This will ensure 100% coverage. Repeat these steps for successive specified grid layers.

**ROCKWOOD<sup>®</sup>**  
RETAINING WALLS  
*A better way.<sup>™</sup>*

# Geosynthetic Reinforcement

## Geosynthetic Reinforcement - Outside 90° Corner

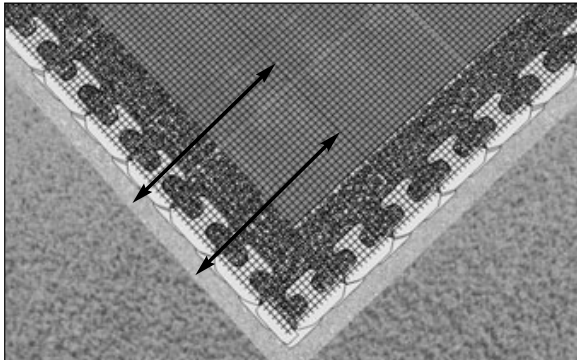

### Step 1 - Grid Placement

On an outside 90° corner, it is important that grid layers do not overlap at the corner. Place the first grid layer per plan at its design elevation and length.

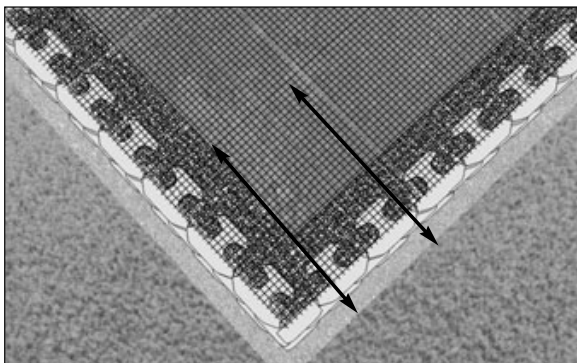

### Step 2 - Successive Grid Layers

In the corner and on the next course of blocks, place a layer of grid perpendicular to the previous layer of grid. Repeat these steps for successive specified grid layers.

## Geosynthetic Reinforcement - Inside 90° Corner

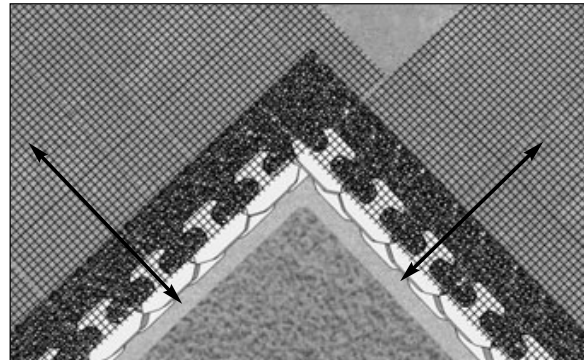

### Step 1 - Grid Placement

Extend the grid past one edge of the wall by a minimum of 2'. Along the other edge, place the grid to the corner.

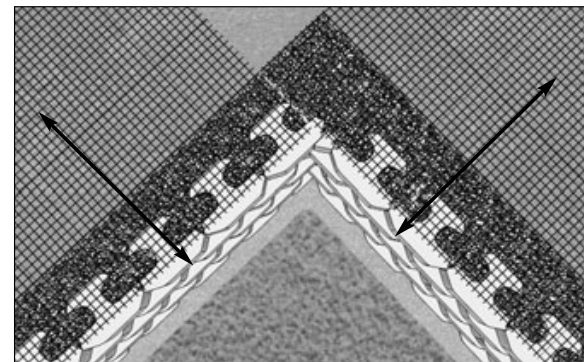

### Step 2 - Successive Grid Layers

At the next designed grid layer, alternate the edge on which the grid is extended past the corner. Repeat these steps for successive specified grid layers.



#### Free Prelims

Be sure you have Rockwood's engineers create a Prelim (Preliminary Material Quantity Take-off) before you bid commercial wall projects. Project Prelims using Rockwood products are done at no charge.

For engineering assistance, contact your regional Rockwood sales representative or call 888-288-4045.

Visit us on the web at: [www.rockwoodwalls.com](http://www.rockwoodwalls.com)

# Specification Installation Instructions

Made in the USA

## Suggested Spacing

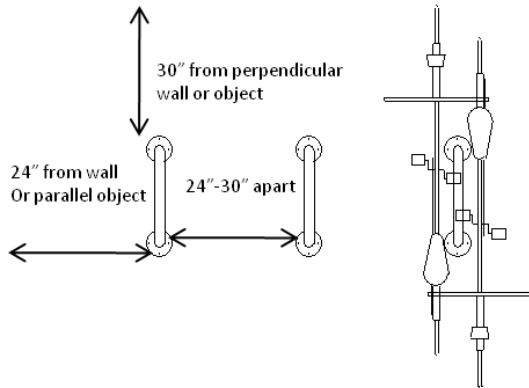

## Mounting Options

(excludes Bike Rib 1.5)

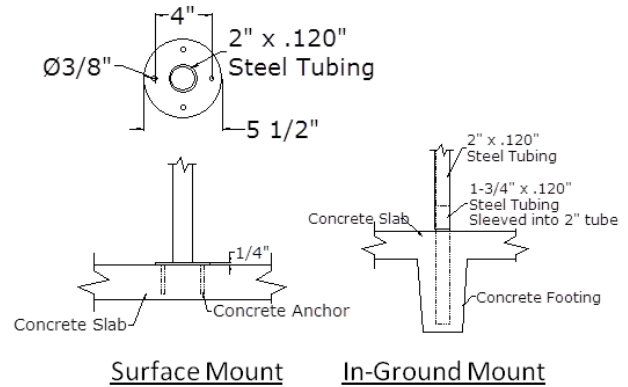

## Suggested Fasteners



### 1/4" Nail drive

- Fast and easy
- Use on solid concrete
- Permanent installation
- Install w/ rack in place



### 1/4" Lag w/ Shield

- Use on asphalt
- Removable installation



### 1/4" Drop-in w/ SS button head bolt

- Use on solid concrete
- Removable installation



### 1/4" Powers WedgeBolt®

- Fast and easy
- Use on solid concrete
- Removable installation
- Install w/ rack in place



### 1/4" Powers Spike®

- Fast and easy
- Use on solid concrete
- Permanent installation
- Install w/ rack in place



Function First Design, LLC

[www.BikeRack.com](http://www.BikeRack.com)

520-322-9626

120 S. Houghton Rd.

Suite 138-153

Tucson, AZ 85747

[www.BikeRack.com](http://www.BikeRack.com)

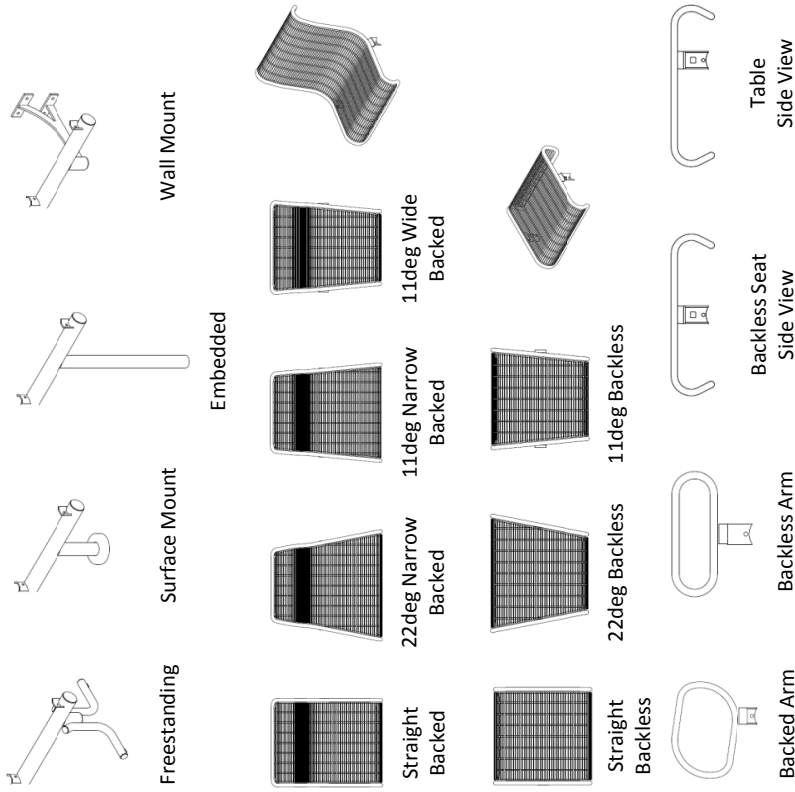

**Included components:**

- 7/16-20 x 1-1/2" hex head cap screw (2 per seat)
- 7/16-20 hex finish nut (2 per seat)

All hardware is stainless steel with lubricating and locking thread patch.

**Tools required:**

- 5/8" socket with flex head handle
  - 11/16" box wrench
- Anchoring hardware: Not included. Corrosion-resistant hardware is recommended.  
 Maximum 3/8" diameter bolts recommended.  
 For Surface Mount: Each support has (6) 9/16" diameter holes for anchoring.  
 For Wall Mount: Each support has (8) 9/16" diameter holes for anchoring.

Date: February 1, 2012

**ASSEMBLE WITH CARE!** Pangard II® Polyester Powdercoat is a strong, long-lasting finish. To protect this finish during assembly, place unwrapped powdercoated parts on packaging foam or other non-marring surface. Do not place or slide powdercoated parts on concrete or other hard or textured surface – this will damage the finish causing rust to occur. Use touch-up paint on any gouges in the finish caused by assembly tools.

**Freestanding Installation:**

1. Set unit in place.
2. Adjust glides as necessary to level bench.

**Freestanding with Couplers Installation:**

Coupling hardware is included. (2) 1/2-13 x 1-1/2" hex head bolts and (2) 1/2-13 hex nylock nuts are included with each support. Tools required: 3/4" wrenches.

1. Set units in place. Horizontal support tubes should be aligned and butted end-to-end. Units with couplers have 5/8" diameter holes on the ends of the supports, with access notches on the underside of the support.
2. Install hex head bolt through holes of both supports. Secure with hex nut. See Fig. 3.

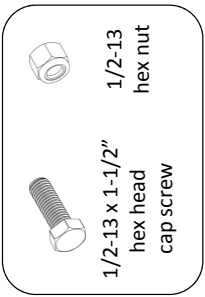

Fig. 1 – Coupling hardware

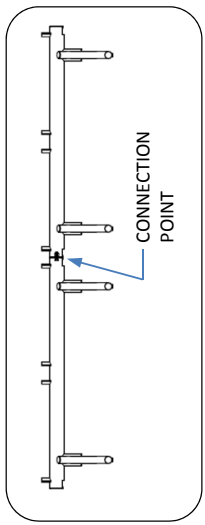

Fig. 2 – Coupling location

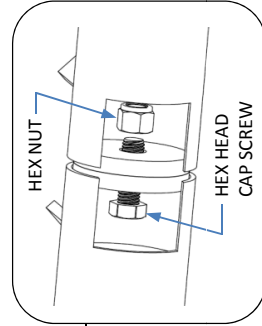

Fig. 3 – Coupling connection

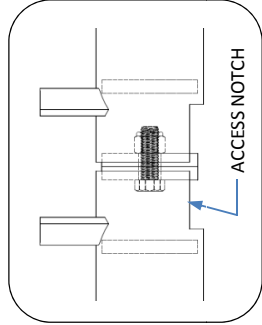

Fig. 4 – Coupling hardware installed



**Freestanding with Anchor Tabs, Surface Mount or Wall Mount**

**Installation:**

1. Set unit in place. Place all units that are to be installed in a group before anchoring any of them. Horizontal support tubes may be aligned and butted end-to-end.
2. Mark hole locations. See Fig. 5 for freestanding with anchor tab details. See Fig. 6 for surface mount plate details. See Figs. 7, 8 and 9 for wall mount details.
3. Move unit to allow access for drilling holes.
4. Drill holes at marked locations according to anchor manufacturer's recommendations. Minimum 2-1/2" anchor depth is recommended.
5. Move unit back into place and install anchors.

**Embedded Installation:**

1. Set unit in place.
2. Mark hole locations.
3. Move unit to allow access for excavating holes.
4. Excavate area for each vertical support as shown in Fig. 10.
5. Set unit in place and secure before pouring concrete. Clean any excess concrete off of support tube.

**Seat, Table and Arm Installation:**

1. Place seat or table on support tube, aligning mounting adapters.
2. Install arms, if specified, as shown in Fig. 12. Backed seats have left and right style arms, as determined by sitting in the seat. Straight backless seats have a universal style arm. Angled backless seats have a left and right style arm.
3. Using hardware provided, insert cap screw through adapters and install the hex nut on the inside of the bracket. See Fig. 11 or Fig. 12. Repeat for other side.
4. Tighten hardware on one side halfway, and then tighten the other side halfway. Repeat until each side is securely fastened. Tighten to 40 ft.-lbs.

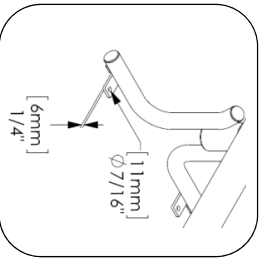

Fig. 5 – with anchor tabs

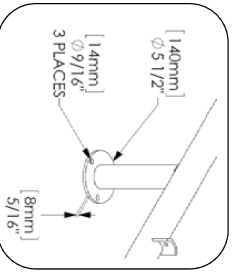

Fig. 6 – Surface Mount

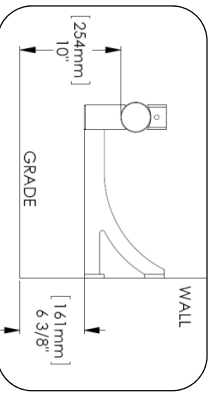

Fig. 7 – Wall Mount Up for backed seats

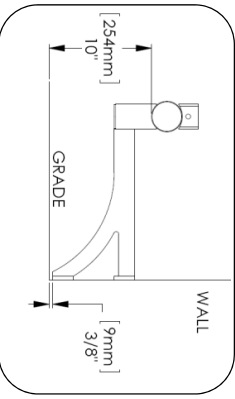

Fig. 8 – Wall Mount Down for backless seats

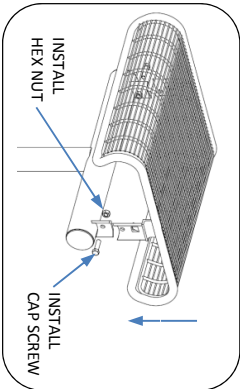

Fig. 11 – Seat install – no arm

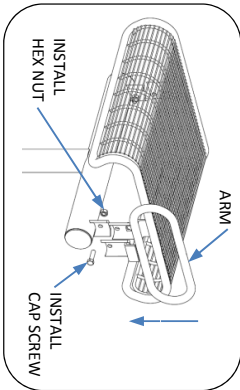

Fig. 12 – Seat install – with arm

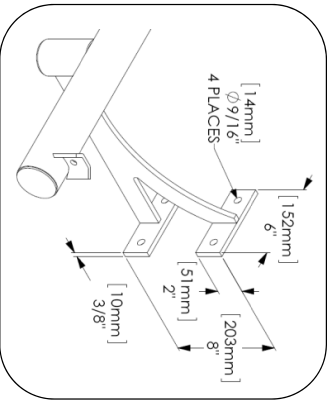

Fig. 9 – Wall mount bracket detail

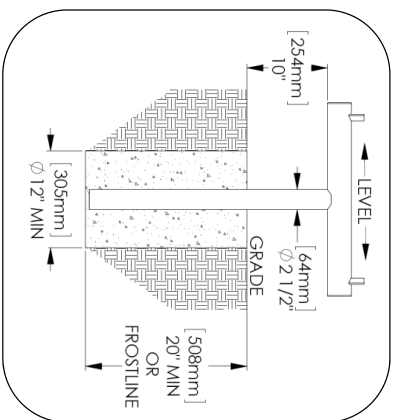

Fig. 10 – Embedded

10/2014

## Carousel Table with Four Seats

### Table Components:

- (2) table/seat supports
- (1) table top
- (4) seats

Note: Marneaux tabletop ships with a circular adapter plate installed, do not remove.

### Hardware:

- (18) 1/4" x 3/4" Phillips tapping screws for Steelhead and Catena table top OR
  - (4) 1/4-20 x 3/4" Phillips machine screws with washers for Marneaux table tops
  - (6) 3/8-16 x 1" hex head machine screws with washers for seats
  - (1) 1/4-20 x 2-1/4 Phillips machine screw and lock nut for umbrella (sold separately)
- (Glides for freestanding support and anchor tabs for surface mount support are factory installed.)

### Tools Required:

- #3 Phillips screwdriver for Steelhead, Catena, and Marneaux table tops
- 9/16" socket and ratchet for seat screws

**HANDLE WITH CARE!** Pangard II® polyester powder coat is a strong, long-lasting finish. Protect this finish from damage during assembly. Place unwrapped powder coated parts on packaging foam or other non-abrasive surface. Do not place or slide powder coated parts on concrete or other hard or abrasive surfaces – this will damage the finish causing corrosion to occur. Use touch-up paint to repair any finish abrasions.

### Assembly:

1. Lay table top upside down on a non-marring surface.
2. Place support A (has 5" ring at center) upside down on table top. Insert screws loosely (6 for Steelhead and Catena or 2 at ends of plates for Marneaux).

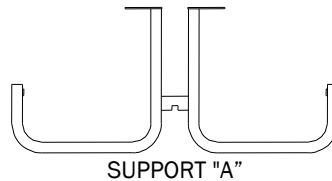

3. Hold support B upside down and carefully lower it over support A. Place bar of support B into notch in ring on support A. Insert screws loosely as before.

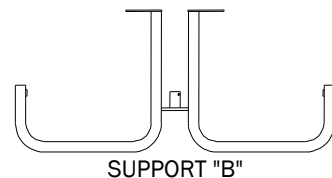

### Carousel Table with Four Seats continued

4. Tighten all table top fasteners until snug, then tighten additional 1/4 turn. **[The use of power drivers is not recommended with Marneaux tabletops. Threaded inserts may be damaged or broken due to over-torquing.]**
5. Turn table right side up, using at least 2 people.

landscapeforms®

Landscape Forms Inc. Office: 800.521.2546  
 431 Lawndale Avenue Fax: 269.381.3455  
 Kalamazoo MI 49048 landscapeforms.com

Page 1 of 2

6. Slip stems on seat bottoms into tubes on support. Assemble backless seats with threaded end of hole or flat side of stem toward center of table. **Carefully align threaded hole in stem with hole in tube. This may require lifting the seat slightly. Insert 3/8-16 x 1" long hex head machine screw with washer through the support hole and tighten. Screws are coated with dry thread locking compound that cures in 24 hours. Wiggle seats and tighten as necessary until seat is securely fastened.**

**WARNING: Seats were NOT designed to swivel. If seating is properly installed and screws are tightened, the seats will not move. Allowing the seating to swivel will damage the finish and the product.**

7. To install umbrella, slide umbrella pole through hole in table and into socket tube on support. Insert 1/4-20 x 2-1/4 screw through holes in socket and umbrella pole and secure with lock nut.

**Recommended procedure for surface mounting to hard-surfacing:**

1. Place unit in desired position. Mark hole locations through anchor brackets.
2. Move unit to allow access for drilling holes.
3. Drill holes at marked locations for appropriate anchors. Note: Anchors must be no larger than 3/8" diameter. Corrosion resistant anchoring hardware is recommended.
4. Although the installer is responsible for anchoring procedure and hardware, we suggest the following:
  - Poured concrete: 3/8" diameter, stud or sleeve type expansion anchor, minimum 2-1/2" long.
  - Pavers: If pavers are installed over poured concrete, use 3/8" diameter, stud type expansion anchor with enough length to go through brick and into concrete.
  - Wood deck (at least 2" nominal thickness): 3/8" diameter hex head lag bolt, at least 2" long.
5. If using expansion anchors, install anchor leaving approximately 3/4" thread protruding from surface. Place unit in position, install hex nut with washer and tighten carefully to avoid marring finish.
6. If using lag screws, place unit in position, install lag with washer and tighten carefully to avoid marring finish.

# Instructions

Assembly  
Installation  
Operation

7/2007

## Scarborough Bench and Receptacle

### Recommended Procedure for Mounting to Hard-Surfacing:

1. Remove nylon glides from bottom of legs. Be careful not to damage finish. Take great care not to slide unit over concrete or other abrasive surfaces after glides have been removed. Place unit in desired position.
2. Mark hole location through anchor holes. Move unit to allow access for drilling holes.
3. Drill holes at marked position for appropriate anchors.
4. Anchoring procedure and hardware is the responsibility of the installer. Field conditions are beyond the scope of these installation instructions. A maximum 3/8-16 thread size anchor and minimum 2½" embedded depth are basic recommendations for concrete, however type and condition of anchoring surface ultimately determines type and length of anchor. Non-corrosive anchors are recommended.
5. If using expansion stud or sleeve type anchors, enough exposed thread is required to go through anchoring tab, washer and hex nut. Place unit in position, install washer and hex nut. Care must be taken to prevent scratching finish.

**ASSEMBLE WITH CARE!** Pangard II® Polyester Powdercoat is a strong, long-lasting finish. To protect this finish during assembly, place unwrapped powdercoated parts on packaging foam or other non-abrasive surface. Do not place or slide powdercoated parts on concrete or other hard or abrasive surfaces – this will damage the finish causing rust to occur. Use touch-up paint to repair any finish abrasions.